



Competition Regulations

2011-2012

Rules Governing Model Aviation Competition in the United States

Control Line Precision Aerobatics

Amendment Listing

Original Issue	1/1/2011	Publication of Competition Regulations

CONTROL LINE PRECISION AEROBATICS

For event 322, 323, 324, 325, 326.

1. Applicability. All pertinent AMA regulations (see

sections titled Sanctioned Competition, Records, Selection of Champions, and General) and the Control Line rules shall apply, except as specified below.

2. Model Requirements and Contestant

Classification. Permitted power source(s) shall include any power except rocket motors. Piston engine(s) shall be subject to a total swept volume limitation of 15cc (0.92 cubic inches). Electric power shall be limited to a maximum no-load voltage of 42 volts. Gas turbine engines shall be limited to 3.5 kg (7 lbs, 11 ozs) static thrust. There is no adjustment allowance for the swept volume displacement of four- stroke cycle engines as specified in Paragraph 11.1., General Control Line rules. No combination of jet, turbine, electric, or reciprocating engine installation will be allowed.

2.1. Stunt Contests may be organized into classes at the discretion of the organizers. These rules may be applied to either classes related to the AMA Age classes (Events 322, Junior, Senior, and Open) or Skill Classes (Events 323-326), or a combination. Classes of some sort are recommended, but not required.

2.2. Contestants will be allowed the use of a second model if the first is damaged or destroyed. Appearance points will be awarded to the second

model following verification of substantial damage to the first model. The second model and its appearance points will be used for subsequent attempts.

2.3. All models shall be identified by the contestant's AMA license number permanently affixed to the upper side of the right-hand lifting surface or to each side of the fuselage or vertical stabilizer. The height of numerals shall be at least one (1) inch (25.4 mm). Both stroke and width shall be such to enable ready recognition. It is suggested that the letters USA (25mm [1 inch] or higher) be placed at least once on the model.

2.4. Maximum model weight including any batteries but excluding fuel is 3.5 kg (7 lbs, 11 oz).

3. Safety Provisions. The control handle/device, thong, connections, lines and internal control system of the model, up to the point of attachment to the model (e.g., bellcrank or other device) will be in good condition, free of kinks, rust, etc., regardless of whether the equipment has already withstood the pull test. The judges' opinion will be final in regards to safeness of a model or equipment. Judges shall exert their authority to disqualify a model deemed unsafe for flight. Safety precautions must be adhered to by the contestant while the model is in flight, with unnecessary and/or persistent low flying under 1.20 meters (3.9 feet) being grounds for deduction of points or disqualification. The flier will retain the control handle in his hand at all times during which

Model Weight (ounces)	Required Line Length (meters)	Required Minimum Diameter of Each Line (mm)					Pull Test
		Single Strand			Multi-Strand		
		1 Line	2 Lines	3 Lines	2 Lines	3 Lines	
0 - 14	7.62 - 21.34	0.356	0.203	-	0.203	-	10G
14.01 - 40	7.62 - 21.34	0.356	0.254	-	0.305	-	10G
40.01 - 64	7.62 - 21.34	0.356	0.305	-	0.381	-	10G
64.01 - 90	7.62 - 21.34	0.406	0.356	-	0.457	-	10G
90 - 123	7.62 - 21.34	0.533	0.457	-	0.533	-	10G

Model Weight (ounces)	Required Line Length (feet)	Required Minimum Diameter of Each Line (in)					Pull Test
		Single Strand			Multi-Strand		
		1 Line	2 Lines	3 Lines	2 Lines	3 Lines	
0 - 14	25 - 70	0.014	0.008	-	0.008	-	10G
14.01 - 40	25 - 70	0.014	0.010	-	0.012	-	10G
40.01 - 64	25 - 70	0.014	0.012	-	0.015	-	10G
64.01 - 90	25 - 70	0.016	0.014	-	0.018	-	10G
90 - 123	25 - 70	0.021	0.018	-	0.021	-	10G

Electric powered measured model weight includes weight of batteries.

Maximum weight for any Control Line Precision Aerobatic model is 3.5 kg (7 lbs, 11 oz).

the model is in motion.

3.1. A pilot's circle shall be clearly marked. That circle shall have a minimum radius of three (3) feet but not larger than five (5) feet in radius.

4. Control Lines. As per the charts.

4.1 Refer to the control line general rules for control line materials and line construction.

5. Pull Test. As per the charts. Pull tests shall be performed immediately before each flight. The method of holding the model for the pull test as specified in the Control Line General rules shall not apply to CL Precision Aerobatics. Considering the fragile construction of Precision Aerobatics models, they may be held in any manner as long as no bodily contact is made with the leadouts, flying wires, or any other element of the control system.

6. Landing Gear. The landing gear must consist of any combination of permanently affixed wheel(s) and/or skid(s) which allow the model to take off and land under its own power in a normal manner. Any main landing gear or other appendages affixed to the model which, in the judges' opinion, are unrealistic or impractical for use on full-size, man-carrying aircraft, will not be allowed. Drop-off gear or similar takeoff devices are not permitted. If a retractable gear is used for takeoff, it must extend to its original position for landing.

7. Flight Procedure. Each contestant will be called to the circle when it is his or her turn to fly. From the time they are called to the circle, contestants will have a maximum of five (5) minutes to give the hand signal to begin starting their engine(s). Once the starting hand signal has been given, contestants will be allowed a maximum of three (3) minutes to become airborne. A contestant may make as many starts as necessary, or may take off, land and restart if necessary, as long as the three minute time period has not been exceeded. If a second takeoff is made during the three minute time period, the first takeoff score will be canceled and a new score given. Failure to give the starting hand signal within five minutes of being called to the circle, or failure to become airborne within three minutes of giving the starting signal, shall be charged as an attempt. Contestants shall be allowed three (3) attempts to make two (2) official flights.

7.1. AMA Nationals Procedures. A procedure with periods of qualification, semifinals and finals which uses more than three (3) attempts, two (2) officials, and which accumulates points from more than the single best flight may be used at the AMA National Championships.

8. Duration of Flights. Eight (8) minutes total elapsed time is allowed from the time the contestant gives a hand signal prior to starting his engine (this should be done with a prearranged plan, and upon signal to or from judges) to start, take off, complete the flight pattern and land. No maneuver, including the landing, will be scored after the eight (8) minutes allowed have elapsed. No restriction is placed on maneuvers a contestant may wish to practice between completion of the pattern and landing; however, a contestant may be disqualified, or points may be deducted from his total score, if he indulges in any manner of unsafe flying during this free period.

9. Judges and Scoring. There is no substitute for experienced judges. When experienced judges are not available, the Contest Director should arrange for practice judging. No judge should start the day "cold." Usually there are contestants available who are willing to fly a pattern for practice judging. If this practice procedure is followed, judges must not discuss the flier's pattern or divulge the potential score of the flier in any manner. If possible, judges should not alternate or be substituted during the entire period in which any given age classification is being judged. If the event is divided into age classifications but with a prize for most points regardless of age, all ages should fly before the same judges if possible. Seldom do judges score alike; thus it may place some contestants at a disadvantage if all do not fly before the same judges. Wherever possible, each judge shall have an assistant whose duty it shall be to mark score sheets as the judge calls out the scores. In this way, the judge need never remove his eyes from the model.

9.1. Scoring shall be based on the appearance of the model and the degree of perfection with which maneuvers are performed. The contestant's flight point score for competition purposes shall be the average of the scores given by no less than two (2) judges. Flight points used shall be those accumulated during the better of the two (2) official flights permitted.

9.2. A contestant shall be permitted to attempt his second official flight when it is his turn even though other contestants may not have completed first flights. Scores shall not be withheld from contestants; preferably, scores should be posted as soon as possible after each flight is completed for all to see.

9.3. The score sheet at the conclusion of this section is recommended by the CL Aerobatics Contest Board, but any other system with which the judges are familiar may be used, provided it is at least as comprehensive as the one recommended. (As scoring is very important for this event, the CB is constantly looking for improvements. Suggested

improvements should be sent to AMA Headquarters for forwarding to the CB Chairman.)

10. Appearance. Models shall be judged for appearance complete and ready to fly. After model has been judged, nothing will be removed from or added to the model which, in the judges' opinion, changes in any manner the appearance of the model from the way it was when presented for appearance judging. However, during an attempt for official flight after the contestant has begun to crank the engine, if it becomes necessary to remove the propeller spinner for change of propeller, etc., then it is permissible to leave off the spinner for that particular flight. Any damage to the model after judging, or changes that may be made as a result of such damage, will not be cause for loss of appearance points. Appearance judging will take place just before contestant's first flight. Judges shall exercise prudence in assigning points, and reserve excellent point values for those models which are decidedly above average.

Appearance (Minimum-0 Maximum-20)

10.1. Appearance points are added to the contestant's flight points for scoring purposes.

11. Flight Pattern. Twenty-five flight pattern points shall be awarded a contestant who successfully completes the entire pattern as listed below. Maneuvers shall be accomplished in the order listed below under "Maneuvers." Each maneuver may be attempted only once. Not doing the correct number of consecutive maneuvers, doing less than two (2) laps between maneuvers, entering or exiting a maneuver in any way other than is illustrated in the maneuver section, and doing an incomplete maneuver all will result in a loss of pattern points. No pattern points will be awarded if maneuvers are attempted but not completed. Omitting any maneuver, either intentionally or otherwise, or completing a maneuver out of its proper order shall result in loss of flight pattern points. If desired, a contestant may notify the judges prior to the flight as to the specific maneuvers he wishes to omit in order that the judge will not be confused as to what maneuver to follow but this will result in loss of pattern points. A crash or failure to complete the pattern due to engine failure shall also result in loss of pattern points. Exceeding the eight (8) minute total elapsed time limit will cause loss of points on any maneuvers performed after the time limit, as well as loss of flight pattern points.

11.1. Attempted/Incomplete Maneuvers.

The model enters the starting point of any maneuver but that maneuver is not fully completed. The attempted/incomplete maneuver shall be awarded a minimum score of 10.

11.2. At least two (2) laps of level flight shall precede each maneuver, including landing. *(A nominal interpretation of the "two (2) lap" level flight requirement is the accepted interpretation, allowing the starting point of one (1) maneuver to begin slightly less than two (2) full laps after the exit point of the prior maneuver due to the width of the maneuvers.)* The two laps between maneuvers need not be at normal level flight attitude. Except for the Overhead Figure Eights, Judges shall not require more than two (2) nominal level laps between maneuvers due to the time limit imposed by these regulations. At least two and a half (2 ½) nominal laps must be flown between the Hourglass Figure and the Overhead Figure Eights. Level flight at an altitude of from 1.20 to 1.80 meters (3.9 to 5.9 feet) will be considered normal level flight, regardless of the height of the flier. Level, for purposes of Precision Aerobatics, means flight along a horizontal plane (perpendicular to vertical); it explicitly does not mean a constant height above the terrain over which the airplane flies. The portions of certain maneuvers which require normal level flight elevation must be accomplished between 1.20 and 1.80 meters (3.9 and 5.9 feet) for maximum points. The elevation reference shall be the height at the center of the pilot's circle. In cases where uneven terrain makes this impractical or unsafe, and alternate reference shall be determined by the organizers and announced at the pilot's meeting. Fliers and judges alike shall note that maneuvers shall be flown and judged in relation to two (2) or three (3) reference points, depending upon the particular maneuver. For example, loops shall be performed with bottom track at approximately 1.50 meters (4.9 feet) elevation, and the top track at 45 degree elevation of the lines; the vertical eight shall also have the approximate 1.50 meter (4.9 foot) lower track elevation, and the top of the figure(s) shall not be more or less than 90 degrees from horizontal, or directly over the flier's head. The reference points (level flight, angular dimensions, etc.) are absolute references and independent of each other. The execution of one maneuver does not affect the references for another. For example, flying lower than 5 feet on the takeoff and level flight does not alter the 5 foot reference altitude. When performed after the completion of the Four Leaf Clover maneuver but before the start of the Landing maneuver, other maneuvering shall be permitted. All such maneuvers shall not be officially observed nor scored by the judges. After takeoff and level flight, and prior to the flight becoming official on turning inverted in the Reverse Wingover, "warm-up maneuvers" are permitted."

12. Official Flight. The flight will become official either when a foul occurs per CL General paragraph 9 or when the aircraft turns into the inverted part of the

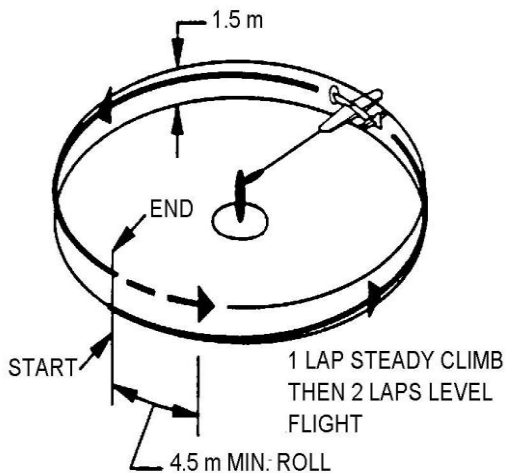

Reverse Wingover. If a foul per CL General paragraph 9 has not occurred, the pilot has the right to call off the flight at any time before this maneuver by signaling the judges.

13. Flight Maneuvers and Scoring. Illustrations are for counterclockwise flight; reverse for clockwise flight. The maneuver descriptions of this paragraph 13 take precedence over any differences that might appear in the respective maneuver diagrams. The “wind arrows” indicating maneuver orientation with respect to the wind are for guidance only. There is no penalty for not adhering to the suggested wind direction aside from a potentially lower maneuver scores caused by making the judge’s evaluation of the maneuver more difficult.

13.1. Takeoff. A correct takeoff consists of the model rolling smoothly along the ground for a distance of not less than 4.5 meters (14.8 feet), but not greater than one quarter of a lap. The model then rises smoothly into the air with a gradual climb and a smooth level-off to normal flight level over the point at which the model commenced its ground roll. The model continues on for two (2) smooth laps of normal level flight to point of original level-off. Maximum 40 points. Minimum 10 points.

Errors: The model bounces or becomes airborne too soon, or too late. Takeoff, climb or level-off is not gradual and is smooth. Level-off occurs too soon, or too late. Level-off and normal flight level are not within a height of 1.2—1.8 meters (3.9—5.9 feet).

13.2. Reverse Wingovers (One Required).

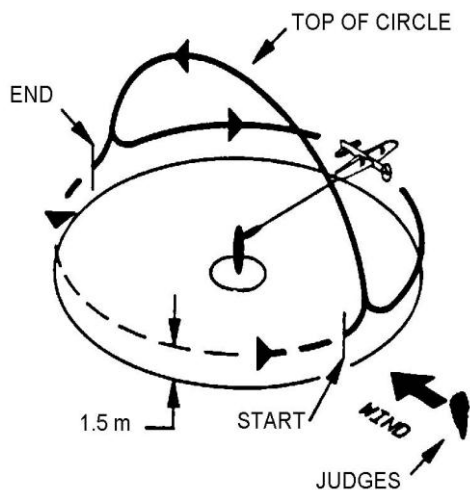

Correct reverse wingovers are judged when the model starts from normal flight level, makes a vertical climb and dive, passing directly over the flier’s head, cutting the ground circle in half, and recovers in an inverted position at normal flight level. The model continues for half a lap inverted, to the starting point, then makes a vertical climb and dive over the center of the circle from inverted flight, recovers at normal flight level. All turns to and from normal level flights shall be of a tight radius. Maximum 40 points. Minimum 10 points.

Errors: First half: The model starts at other than normal flight level, wobbles when going into climb and/or the turn is not of a tight radius. The model does not cross directly over the flier’s head. The

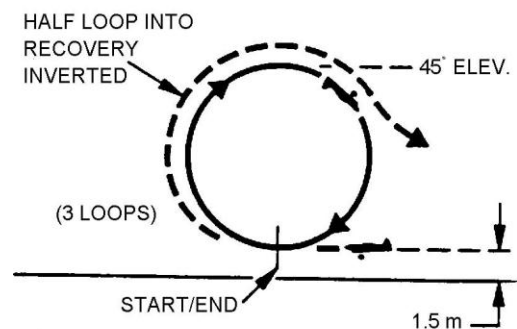

model does not cross the circle in a straight line. The model wobbles or recovers at other than normal flight level in an inverted position or the turn is not of a tight radius. The model does not cut the circle in the same position and direction in the second part of the maneuver. Second half: Scored same as first half, reversing the entry and recovery positions.

13.3. Consecutive Inside Loops (Three (3) Required). Correct loops are judged when the model starts from normal flight level and makes a series of three (3) smooth, round loops, all in the same place with the bottoms of the loops at normal flight level and the tops of the loops with the line(s) at 45 degrees elevation. The model then continues for another half loop, recovering inverted and descending to normal flight level, flying two (2) laps before being judged for inverted flight.

Maximum 40 points. Minimum 10 points.

Errors: Loops are rough and irregular (i.e., egg - shaped, hexagonal, etc.). Bottoms of loops are not at 1.2–1.8 meters (3.9–5.9 feet) height. Tops of loops vary more than 0.6 meter (2 feet), plus or minus, of the 45 degrees elevation point. Second and third loops vary more than 0.6 meter (2 feet) from the path of the first loop.

13.4. Inverted Flight (Two (2) Laps).

Correct inverted flight is judged when the model makes two (2) smooth, stable laps at normal flight level.

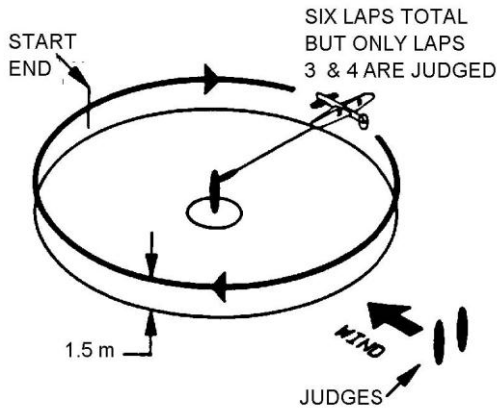

Maximum 40 points. Minimum 10 points.

Errors: Height is not 1.2—1.8 meters (3.9—5.9 feet). Height varies more than 0.6 meter (2 feet).

13.5. Consecutive Outside Loops (Three (3) required). Correct loops are judged when the model starts from inverted position at normal flight level and makes a series of three (3) smooth, round loops, all in the same place, with the bottoms of the loops at normal flight level and the tops of the loops with the line(s) at 45 degrees elevation. The model then continues for another half loop, recovering at normal flight level.

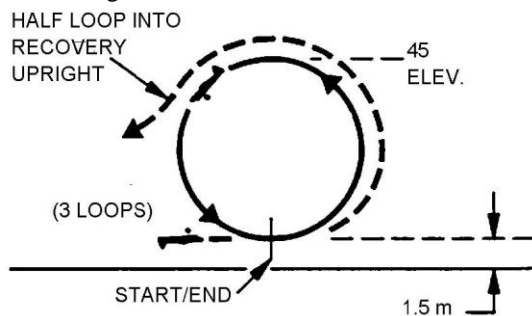

Maximum 40 points. Minimum 10 points.

Errors: Loops are rough and irregular (i.e., egg-shaped, hexagonal, etc.) Bottoms are not at 1.2—1.8 meter (3.9—5.9 feet) height. Tops of loops vary more than 0.6 meter (2 feet), plus or minus, of the 45 degrees elevation point. Second and third loops vary more than 0.6 meter (2 feet) from the path of the first loop.

13.6. Consecutive Inside Square Loops

(Two (2) required). Consecutive inside square loops are judged correct when the model starts from normal flight level and flies a square course consisting of two (2) loops, each with four (4) inside turns which shall be of a tight radius and (4) straight segments with bottom segments at normal flight level and top segments as inverted level flight at 45 degrees elevation. The two (2) bottom corners are equal and so are the two (2) top corners. The maneuver begins and ends with the model in level flight at the point of start of the first turn.

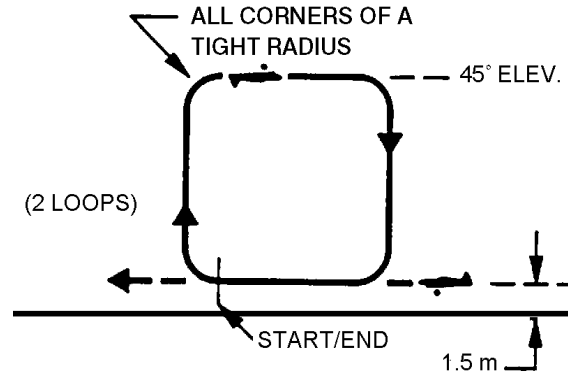

Maximum 40 points. Minimum 10 points.

Errors: Model wobbles on turns. Lower height is not between 1.2—1.8 meters (3.9—5.9 feet). Upper height is not within 0.6 meter (2 feet) of the 45 degrees elevation point. Turns are not precise and/or are not of a tight radius. Sides of loops are not equal. Second loop is not in the same flight path as the first loop.

13.7. Consecutive Outside Square Loops

(Two (2) required). Consecutive outside square loops are judged correct when the model starts from level flight at 45 degrees elevation and flies a square course (starting with a vertical dive) consisting of two (2) loops, each with four (4) outside turns of a tight radius and (4) straight segments with bottom segments inverted at normal flight level and top segments as level flight at 45 degrees elevation. The two (2) bottom corners are equal and so are the two (2) top corners. The maneuver begins and ends with the model in level flight at the point of start of the first turn. The model recovers into normal level flight.

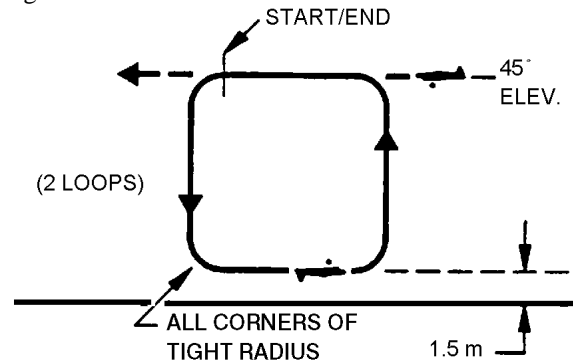

Maximum 40 points. Minimum 10 points.

Errors: Model wobbles on turns. Lower height is not within 1.2—1.8 meters (3.9—5.9 feet). Upper height is not within 0.6 meter (2 feet) of the 45 degrees elevation point. Turns are not precise and/or are not of a tight radius. Sides of loops are not equal. Second loop is not in the same flight path as the first loop.

13.8. Consecutive Inside Triangular

Loops (Two (2) required). Correct triangular loops are judged when the model starts from normal level flight and flies a triangular course, starting at the base

turn. The three (3) sides of equal length and the three (3) corner angles of equal size. The top corner must be placed at 45 degree elevation. The second triangular loop must be flown in the same flight path as the first one. All corners must be smooth, precise and shall be of a tight radius.

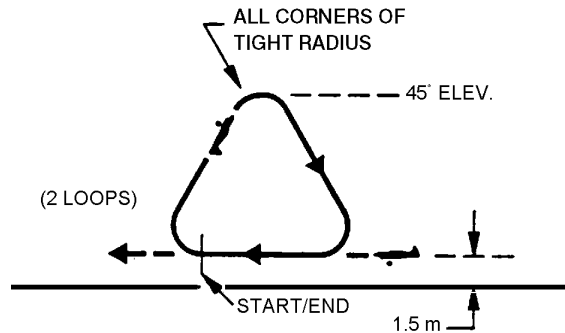

Maximum 40 points. Minimum 10 points.
Errors: Model starts at a height other than between 1.2—1.8 meters (3.9—5.9 feet). Turns are rough and wobbly and/or are not of a tight radius. Peak of second turns is not within 0.6 meter (2 feet) of the 45 degrees elevation point. Sides are wobbly and not equal in length. Second loop is not in the same flight path of the first loop.

13.9. Horizontal Eights (Two (2) required).

Horizontal eights are to be entered and completed at the intersection point of the circles and exit at the same point. The inside loop must be flown first. Correct eights are judged when the model makes two (2) eights, each consisting of two (2) round circles or loops of the same size, tangent to each other, and in a horizontal line. The model must enter the eight from normal flight level and be vertical at the intersection point of tangency of the circles. The eights must be symmetrical. At the top of each circle the model must be at the 45 degrees elevation point; the bottoms of circles must be at normal flight level.

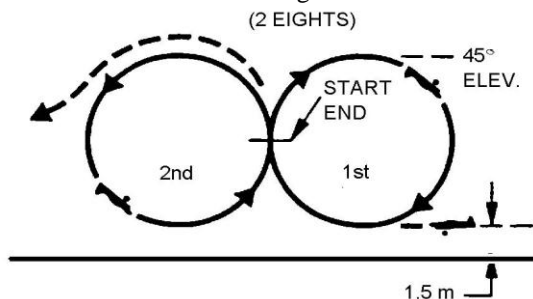

Maximum 40 points. Minimum 10 points.
Errors: Model is not vertical at entry. Model at top of circles is not within 0.6 meter (2 feet) of 45 degrees elevation point. Bottoms of circles are not within 1.2—1.8 meters (3.9—5.9 feet) height. Loops are not round and equal in size. Point of intersection

varies. Second eight is not in the same position as the first.

13.10. Square Horizontal Eights (Two (2) required). The eight is to be entered in the direction of the climbing sides of the loops, and after completion of two (2) eights the exit is made in the same direction. The inside loop must be flown first. Correct eights are judged when the model starts a vertical climb and makes a modified inside square loop followed by a modified outside square loop ending with a vertical climb at the same point. The loops are modified so their climbing sides are vertical, and the loops are tangent to each other along these sides, and the turns starting and ending the climbs are 90 degrees. The top sides are slightly shorter than the remaining sides which are of equal length. The maneuver is repeated to form two (2) eights. Tops of loops must be at 45 degrees elevation, bottom of loops must be at normal flight level, and all turns must be smooth, precise, and shall be of a tight radius.

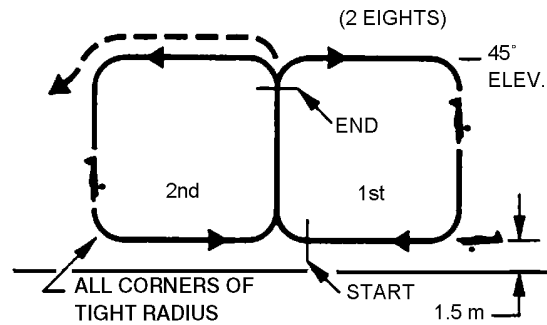

Maximum 40 points. Minimum 10 points.
Errors: Corners shall be of a tight radius. Sides are not straight. Vertical sides and bottom sides are not equal in length. Loops are not equal in size. Top and bottom sides are not horizontal. Turns starting and ending the climbs are not 90 degrees. Tops of loops are not within 0.6 meter (2 feet) of 45 degrees elevation. Bottom of loops are not within 1.2—1.8 meters (3.9—5.9 feet) in height. The position of the climbing side varies. Second eight is not in the same position as the first one.

13.11. Vertical Eights (Two (2) required).

Vertical eights are to be started at the point of 45 degrees elevation and finished at the same point in inverted flight. The inside loop must be flown first. Correct eights are judged when the model makes two (2) eights, each consisting of two (2) round circles or loops of the same size, tangent to each other, and in a vertical line. The model must be horizontal at the intersection point of tangency of the circles. The eights must be symmetrical, the top of the eights at a point 90 degrees over the flier's head, and the bottom of the eights at normal flight level.

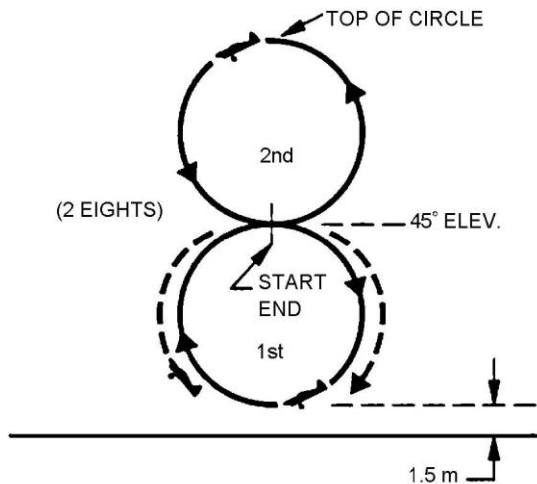

Maximum 40 points. Minimum 10 points.
Errors: Model is not horizontal at entry. Entry is not within 0.6 meter (2 feet) of the 45 degrees elevation point. Tops of eights are not within 0.6 meters (2 feet) of the 90 degree point. Bottoms of eights are not at a height between 1.2—1.8 meters (3.9—5.9 feet). Loops are not round and equal in size. Point of intersection varies. Second eight is not in the same position as the first.

13.12. Hourglass Figure (One (1) required).

The correct hourglass figure is judged when the model starts from normal flight level and flies an hourglass course starting with an abrupt turn followed by an inverted climb, turns into a wingover path across the circle center for a distance equal to half the total climb, turns into an inverted dive, and recovers at normal flight level. The flight paths of the climb and the dive cross at 45 degrees elevation. The four rounded corners of the figure shall be of a tight radius and the flight path forms two (2) equilateral triangles of equal size, turned peak to peak, and one (1) in vertical line above the other.

Maximum 40 points. Minimum 10 points.

Errors: Maneuver starts at other than the normal flight level of 1.2—1.8 meters (3.9—5.9 feet). Turns are rough and wobbly and/or are not of a tight radius. Top of figure is not within 0.6 meter (2 feet)

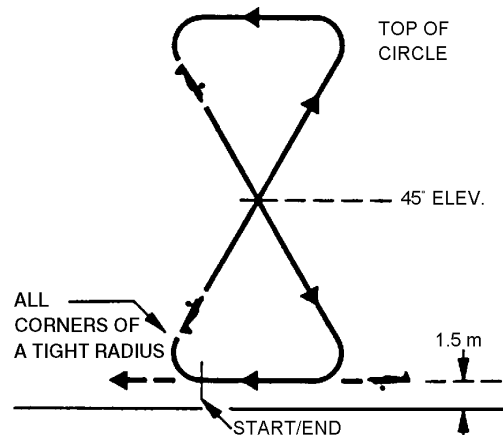
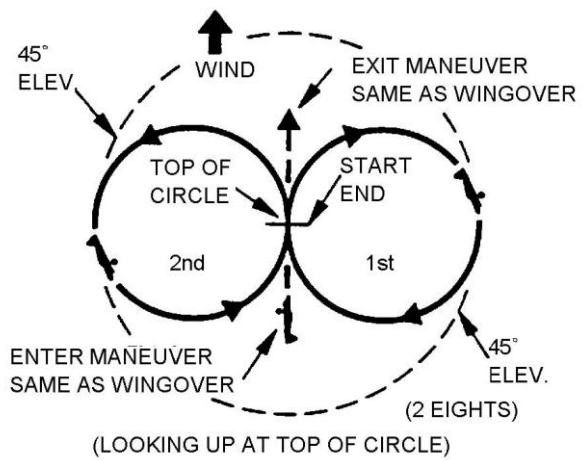

of the 90 degrees position over the pilot's head. Triangle segments are not of equal length. The maneuver is not symmetrical around the vertical line through the crossing point at 45 degrees elevation. Recovery is not at normal flight level of 1.2—1.8 meters (3.9—5.9 feet).

13.13. Overhead Figure Eights (Two (2) required). Overhead eights are to be entered and completed at the intersection point of the circles, directly over the flier's head, and exit from the same point. The inside loop must be flown first. Correct overhead eights are judged when the model makes two (2) eights, each consisting of two (2) round circles of the same size, with the intersection or point of tangency directly over the flier's head. The model must enter the eights with a vertical climb through the center of the circle, and must always point in this direction at the center of the eights. The eights must be symmetrical and the model at the lowest point of each circle must be at a point of 45 degrees elevation. Maximum 40 points. Minimum 10 points.

Errors: Model is not vertically overhead at entry. Low point of circles is not within 0.6 meter (2 feet) of the 45 degrees elevation point. Loops are not round and equal in size. Point of intersection varies. Second eight is not in the same position as the first.

13.14. Four Leaf Clover (One (1) required). The maneuver is entered from level flight

at approximately 42 degrees elevation, and consists of one (1) full inside loop, level flight, three-fourths (3/4) of an outside loop, vertical climb, three-fourths (3/4) of an outside loop, level inverted flight, three-fourths (3/4) of an inside loop, and a vertical climb. The right loops are tangent to the left loops along a vertical plane of symmetry through the center of the clover leaf, and the bottom loops are tangent to the top loops. The loops are of equal size and they are connected by horizontal and vertical flight paths. The bottom points of the maneuver shall be at 1.5 meters (4.9 feet) height, and the top shall be tangent to the vertical plane through the circle center. When the last loop is performed, the maneuver is made complete by a vertical climb through the center of the four leaf clover.

Maximum 40 points. Minimum 10 points.

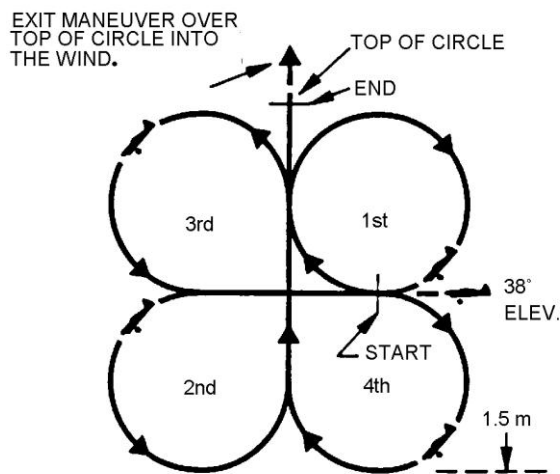

Errors: Entry is not within 0.6 meter (2 feet) of 42

degrees elevation point. Loops are rough or not of equal size. Paths connecting loops are not properly horizontal or vertical according to the maneuver sketch. Bottoms of lower loops are not at a height between 1.2—1.8 meters (3.9—5.9 feet). Tops of upper loops are not within 1.2 meters (3.9 feet) of the vertical plane through the circle center. Loops are not properly tangential to form a square pattern. Model recovers before it has flown vertically through the clover pattern.

13.15. Landing. A correct landing is judged when the model descends smoothly to land with no bounce or unusual roughness, and without any part of the model other than the landing gear having touched the ground. Main wheel(s) or three-point landings are permissible. The duration of the flight ends when the model rolls to a stop.

Maximum 40 points. Minimum 0 points.

Note: Illustrations are for anticlockwise flight and are reversed for clockwise flying.

Errors: An error is committed whenever the model bounces or when any part of the model other than the landing gear touches the ground. A crash, or a flip over, a belly or upside down landing receives no marks. An error occurs each time the model deviates from a smooth descent. Any unusual circumstances, outside the pilot's control, which may have caused one of the above mentioned errors will be taken into consideration by the judges. Note: It is permissible to extend (by whipping) the descent, to achieve the minimum two (2) laps between maneuvers, to maintain eligibility for pattern points.

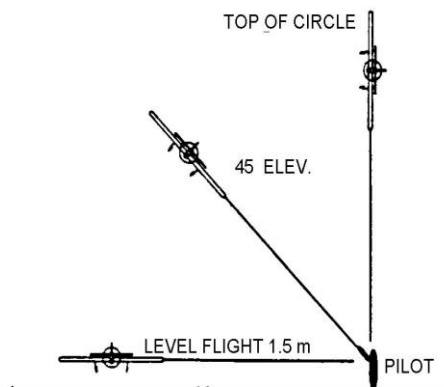

Control Line Precision Aerobatics			
	Maneuver	Points	Score
1	Takeoff and Level Flight	10-40	
2	Reverse Wing Over	10-40	
3	Inside Loops (3)	10-40	
4	Inverted Flight (2 Laps)	10-40	
5	Outside Loops (3)	10-40	
6	Inside Square Loops (2)	10-40	
7	Outside Square Loops (2)	10-40	
8	Triangular Loops (2)	10-40	
9	Horizontal Eights (2)	10-40	
10	Horizontal Square Eights (2)	10-40	
11	Vertical Eights (2)	10-40	
12	Hourglass Figure	10-40	
13	Overhead Eights (2)	10-40	
14	Fourleaf Clover	10-40	
15	Landing	0-40	
16	Pattern Points	0 or 25	
	Appearance	0-20	
		Total	

Flight No. _____ Circle No. _____
 Judge _____

Name _____

AMA No. _____

14. Judges' Guide.

14.1. Purpose. This Judges' Instructions document is an aid to judging and marking Control Line Precision Aerobatics competitions. It should be used both for the training of potential judges, and for maintaining the proficiency of judges who are already practicing. The information in the Judge's guide is strictly advisory and does not define any rules or requirements of the event.

14.1.1. The maneuver descriptions and maneuver diagrams of Paragraph 13 take precedence over any differences that might appear in this Judges' Guide.

14.2. AMA Rules and Maneuver Rules Knowledge. The primary requirements for fair, accurate, and consistent judging are:

14.2.1. A clear understanding of all of the applicable regulations and definitions within the complete AMA rules;

14.2.2. An in-depth and fully detailed knowledge of all of the current Precision Aerobatics maneuver Rules;

14.2.3. A fully detailed knowledge of this complete Judging Instructions document.

Self-study of all of the above points is a must, as is regular detailed group training at both classroom and flight venues in the practical application of all of the above points to the judging of high quality Precision Aerobatics competition flights. It is stressed that individual "interpretation" of the intent and/or meaning of the AMA rules is strongly discouraged—the purpose of these Judging Instructions is to eliminate any need for such "interpretation" by individuals.

14.3. Terminology.

14.3.1. In all of the following maneuver marking instructions, the descriptions have been written from the viewing point of the pilot and **not** of the judges; and all the following descriptions use "two-dimensional" terms on the basis that while it is known that model aircraft actually fly hemispherical arcs, the real judging task is to mark maneuvers such as Square Loops (for example) on the basis of what can be most easily and clearly described in writing as "straight line" flight paths. Rather than using terms which are geometrically accurate but which may create confusion, all the maneuver descriptions in this document therefore use terms which express the meaning of the AMA Rules and explain the judges' marking tasks as clearly and as simply as possible.

Term:	Definition:
Maneuver	Means the full total of figures and segments necessary to complete the marked “flying exercise” listed in the Rulebook under a single Rule number. Examples: the Take-off (Rule 13.1.); the Three Consecutive Inside Loops (Rule 13.3.); and the One Four-leaf Clover (Rule 13.14.). These are all referred to in this document as a single maneuver. Note that each maneuver listed in the Rulebook has a Rule number.
Figure	Means a shape which makes up a separate, recognizable whole portion of a complete maneuver. For example, the first loop of the Three Consecutive Inside Loops (Rule13.3.) is referred to as a figure in this document; but the first loop which makes the first half of the first complete figure eight in the Two Overhead Figure Eights (Rule13.13.) is not referred to as a figure in this document.
Segment	Means a specifically defined part of a figure (or a maneuver) during which the judge is required to observe certain particular detail points. For example, the Two Consecutive Inside Square Loops maneuver (Rule 13.6.). This document has divided that maneuver into two separate figures (the first and second loops) and the first loop has also been subdivided into four separate segments for judges to observe specific detail points.
Upright	Means that the model aircraft is flying in its “normal” attitude (that is: with its main landing gear wheels nearest to the ground).
Inverted	Means that the model aircraft is in an attitude reversed from upright flight (colloquially: the model aircraft is “flying on its back” or is “flying upside-down”).
Vertical	Means at right angles (perpendicular) to the ground over which the flying takes place. This word is marked with quotation marks throughout this document as a constant reminder to judges that the requirement of the Rulebook is for model aircraft to fly at right angles to the ground, even if that ground is not level and/or has a perceptible slope.
Horizontal	Means parallel to the ground over which the flying takes place. This word is marked with quotation marks throughout this document as a constant reminder to judges that the requirement of the Rulebook is for model aircraft to fly parallel to the ground, even if that ground is not level and/or has a perceptible slope.

Straight Line	Means the closest distance between two points when shown in two dimensions. These words are marked with quotation marks throughout this document as a constant reminder to judges that the judging requirement in all the Square and Triangular maneuvers (for example) is to observe a number of turns (“corners”) which should be joined by flight paths which appear to be straight lines when the judges are positioned correctly and when the competitor positions the model aircraft as required in the relevant maneuver Rules.
Momentarily or Momentary	Used throughout this document in their original definition sense—that is: something which lasts only for a very brief period of time. So (for example) the very short period during which the model aircraft is required to be in a vertically banked “knife-edge” attitude above the competitor’s head during the Two Overhead Figure Eights maneuver (Rule 13.13.) is described in this text as “momentarily.”
Lateral Reference	Means an imaginary line drawn upwards from the ground at right angles. The judges should use this as the reference point when observing the size, positioning, symmetry, and superimposing of figures and maneuvers being judged. As required by individual maneuver Rules, the text may refer to a lateral reference, to a lateral reference line, or to a lateral reference point. In this last case the text will also define the specific point (height) on the imaginary line at which the lateral reference point is to be located.
Wingover Path	Means the vertically banked (“knife-edge”) flight path segment defined as part of the One Reverse Wingover maneuver Rule 13.2., see 14.24.4.

When words appear in quotation marks with italics script in the following text, this means that they have been taken directly from the relevant maneuver Rule.

14.3.2. The following “everyday English” terms appear but are used throughout this document in a specific way:

14.4. Judging focus. In order to get complete picture of each maneuver, judges should focus their attention on four major aspects:

14.4.1. Shape. This is the form or outline of the entire maneuver, but shape also relates to the position of each of the figures making up a complete maneuver. In maneuvers consisting of repeated multiple figures (for example: the Four Leaf Clover), an important criteria is that the shape of each individual figure is consistently the same for each repetition. All maneuvers should be of the shape defined in the various maneuver Rules—that is: round loops should be round with no flat spots; square maneuvers should have clearly defined corners connected by “straight line” flight paths; consecutive maneuvers should be performed with the second and subsequent maneuvers all positioned in exactly the same place as the first (superimposed).

14.4.2. Size. Maneuver sizes are defined in the Rules by specifying line elevation angle (specified in degrees of arc above the normal 1.5 meters (4.9 feet) upright level flight height). Judges should watch for maneuvers being flown with their tops above or below the specified 45 degrees, 42 degrees, and 90 degrees line elevation angles—and as a result of such errors, judges should also watch for complete figures which are either larger or smaller than the line elevation angle specified in the relevant Rule. All such errors should be downgraded in the marks awarded by judges. The use of visible fixed terrain reference points at each site to help judges “fix into memory” both the 1.5 meters (4.9 feet) normal

upright and inverted level flight height, and 45 degrees lateral angle (1/8 lap) is recommended. Contest organizers are also encouraged to erect suitable markers at contest sites to assist judges, particularly at sites where suitable natural fixed features are limited. Judges should practice using the available terrain features, plus any erected markers, at each competition site during the calibration flight sessions held before the start of each particular competition (see also 14.15.).

14.4.3. Intersections. The judging (and therefore the marking) of the intersections between the various elements of complex maneuvers is also made easier if judges use fixed terrain reference marks to “fix into memory” the visual position of the model aircraft when it passes an intersection point for the first time in a maneuver, and then compare that “locked-in” point with the position of the model aircraft when it comes to the same intersection point at later stages of the same maneuver. As in 14.4.2. above, the erection of suitable markers is encouraged to assist this practice, particularly at sites which lack suitable fixed terrain reference points (see 14.15.).

14.4.4. Bottoms. Normal upright level flight and inverted level flight is specified in the maneuver Rules as being required to be flown at a height 1.5 meters (4.9 feet), often with an allowed tolerance of plus/minus 30 cm (1 foot). These occasions are all clearly described in the following descriptions and

judges should mark accordingly, as per 14.6., 14.9.2., and 14.9.3.

14.5. General comments regarding the marking of maneuvers. Although model aircraft fly on the surface of a hemisphere, from the pilot’s perspective all maneuvers are flown in plane geometry—because all points on the surface of a hemisphere are at an equal distance from the pilot, the pilot sees all maneuvers as if they were drawn on a flat sheet of paper. From their position outside the circle, judges are, firstly, not in the ideal position to view maneuvers, and secondly, they also usually view maneuvers from a point which is not directly opposite the center line axis of each maneuver.

Therefore the judges’ marking tasks include a large element of personal analysis and situational awareness that should take their own (less than ideal) viewing position into consideration when awarding marks. There are however a number of precise definitions within the maneuver Rules which judges must assess accurately if they are to award fair and consistent marks. These are:

14.5.1. Recognition of level flight altitude of 1.5 meters (4.9 feet), plus/minus 30 cm (1 foot).

14.5.2. Recognition of 45 degrees line elevation height, plus/minus 30 cm (1 foot).

14.5.3. Recognition of 42 degrees line elevation height, plus/minus 30 cm (1 foot).

14.5.4. Recognition of a position directly overhead the center of the flight circle, plus/minus 60 cm (2 feet).

14.5.5. Recognition of “vertical” climbing and diving flight paths.

14.5.6. Recognition of a “horizontal” flight path.

14.5.7. Recognition that “*turns shall be of a tight radius*” are an abrupt change of direction with the resulting requirement for the model aircraft to fly very tight corners (see all 14.7).

14.5.8. Recognition of the correct “Start” and “Stop” points specified in the Rule for each maneuver (as highlighted within the description of each maneuver in this document by means of “Start judging at...” and “Stop judging at...” sections).

14.5.9. Recognition of the fact that all the above “dimensions” are specified as measured from the pilot’s viewing point, with due allowance to be made by judges for model aircraft flown on different line lengths and for the difference between the pilot’s position and the judges’ actual viewing position/s.

14.6. Judging objective errors. Provided that throughout all the judged laps the model aircraft remains inside the tolerance defined in the rules and provided that it tracks smoothly without any visible height changes (that is, no “hunting”) throughout, no downgraded mark should be awarded. A flight track which slightly exceeds the stated tolerance (such as flying 40 cm [1.3 feet] off the flight track where plus/minus 30 cm [1 foot] is required) should be considered as a “minor” error which would cause the judge to award a mark downgraded by 1 point. Flying off the defined flight track by as much as twice the defined tolerance should be considered as a

“medium” error, resulting in the award of a mark downgraded by 2 points. Errors of three times the defined tolerance from the defined flight track should be considered as “major” resulting in the award of marks downgraded by 3 points. In order to use this method successfully, judges must be trained to recognize flight path deviations of 30 cm (1 foot) and 60 cm (2 feet) at a viewing distance of approximately 45 meters (140 feet), and this will require relevant and repeated demonstrations to train judges to be able to readily gauge such measurements. Such training is highly recommended for all judges, and such training should also emphasize the varying tolerances defined in the Rule for each maneuver and for each segment of each figure of each maneuver. See also 14.9.2. and 14.9.3.

14.7. Judging subjective errors.

14.7.1. “Wobbles,” etc; A phrase such as “the model aircraft wobbles during a turn” is subjective, and the degree to which the model aircraft wobbles cannot be measured. Similarly, Rules statements such as “...*the model aircraft makes two smooth, stable laps...*” are difficult to apply when faced with the task of translating a certain lack of smoothness into an actual mark to be awarded to a competitor. As a basic guide, judges should consider terms such as stability and smoothness to be conditions defined by the absence of “wobbles,” “jerks,” and/or “hunting.” Therefore “wobbles,” “jerks,” and/or “hunting” are errors, and each judge should decide on the extent of each such error seen and should award a downgraded mark accordingly to the severity of each of these errors that he/she has observed. See also 14.9.2. and 14.9.3.

14.7.2. Turn radii; Similarly, judges should recognize that the intent of the Rulebook regarding corner radii in maneuvers such as Square Loops, Square Eights, Triangles, etc. is that model aircraft should turn as sharply (tightly) as possible. Therefore, although it is not possible for judges to accurately measure whether or not a model aircraft has or has not made a turn of between 1.5 (4.9 feet) and 2.1 meters (6.9 feet) radius, the intent of the maneuver descriptions is clearly that model aircraft should turn as tightly as possible when making such turns. Therefore judges should award the highest marks to model aircraft turning the tightest (sharpest) corners (provided that the required line elevation angles and/or the model aircraft’s pitch angles have also been achieved) and they should award the lowest marks to model aircraft making the largest (softest) such turns.

14.8. Error interpretation; Each maneuver Rule states which errors shall be considered as errors but nothing is written about the relative importance of those errors. The judges’ task is therefore twofold in this respect—first, he/she has to count the total number of errors committed,—second, he/she must **also** decide on the extent to which each of those errors has deviated from the standard specified in each maneuver Rule. As a general principle it therefore follows that a maneuver which is flown with a large number of major errors should result in judges awarding a lower mark than for a maneuver which is flown with a very large number of

errors, although each of those errors may be individually judged as being only a minor deviation from the maneuver Rule, it could be quite correct to award a lower score for that maneuver than for another maneuver which is flown with only a few errors, but where each of those errors is individually judged as being a major deviation from the maneuver Rule. This is precisely one of the skills that judges are expected to develop and apply! Error interpretation should be used as a guide and training tool for all judging See also 14.9.2. and 14.9.3.

14.9. Awarding marks.

14.9.1. Segmented and multiple maneuvers; Many maneuvers have been described in this document as consisting of several figures, and in many of those maneuvers those figures have in turn been broken down into separate segments for judging purposes. But all these segments and figures should be combined to result in the award of only a single mark for the complete maneuver. In addition, many maneuvers detailed in the maneuver Rules consist of multiple (repeated) figures. Once again judges should award only a single mark for each such maneuver (for example: the Three Consecutive Inside Loops; the Two Horizontal Square Eights; etc.).

14.9.2. Principles of marking; Judges should **only** score (mark) maneuvers between the points “Start judging at...” and “Stop judging at...” as set out in each of the maneuver descriptions in this document. When the model aircraft reaches the “Start judging at...” point for each maneuver, each judge should assume that the maneuver will be flown within all the “dimensions” and other requirements defined in the relevant maneuver Rule. (This maneuver would of course mean that the judge should award the full maximum available 40 points if he/she has seen no errors by the time the maneuver is completed). But as the model aircraft proceeds through the maneuver, each judge will (usually) observe some deviation from the maneuver Rule requirements, so he/she should then mentally deduct point/s from the potential maximum of 40 points whenever a deviation is seen. The number of points to be deducted for each error by each judge will of course depend on whether judgment as to whether each of those deviations is a “minor” error, a “medium” error, or a “major” error, as described in 14.6. above. So after the model aircraft has reached the “Stop judging at...” point

Judges’ Observations:	Mark awarded:
No deviations from Sporting Code “dimensions” And requirements seen:	=Mark 40 points
Very few minor errors seen:	=Marks range 39-34(Note 1)
Few and/or minor errors seen:	=Marks range 33-26(Note 2)
More and/or medium errors seen:	=Marks range 25-18(Note 2)
Many and/or major errors seen:	=Marks range 17-10(Note 3)

for each maneuver, the judges' task is then to total all the points which have been mentally deducted during the maneuver, and the final mark to be entered into the score sheet is simply the maximum available 40 points, minus the total of all the points mentally deducted by the judge while the maneuver was being flown. This deduction method, while not easy to learn, and while requiring a considerable amount of instruction and practice, does offer the advantage of coming very close to producing repeatable results when using a consistent marking bandwidth for weighting each error seen.

14.9.3. Marking bandwidth. The following scale of Marks is listed to provide judges with a practical tool application to principles in 14.9.2. above:

Notes for marking bandwidth table:

Note 1: The number of points actually awarded for each maneuver will be dependant upon the total number of errors seen by each judge and whether or not each judge decides that these are all minor errors only.

Note 2: The number of points actually awarded for each maneuver will be dependant upon the total number of errors seen by each judge and the extent to which each judge decides that each error is either a minor or a medium or a major deviation from the maneuver Rule.

Note 3: As per Note 2, but the mark 0 (zero) points should be reserved for maneuvers which are not attempted at all.

Judges should use the entire Marks bandwidth available as above. This means awarding a Mark of 40 points to any maneuver where the judge does not observe any of the errors listed in the maneuver Rules and/or in this Judging Instructions document—such as an Inverted Flight maneuver where the model aircraft remains truly stable and without “hunting” inside the allowed height tolerance of plus/minus 30 cm (1 foot) throughout all judged laps. But as an example of the opposite extreme, the Square Eights maneuver which is flown with line elevation angles of over 60 degrees, with “soft” corners, with angled sides, with slanted tops, with pullouts which are both too high and too low, and with intersections which are missed by several meters (in other words, a maneuver which is barely recognizable), should be awarded a mark of perhaps 10 to 15 points. **Note once more the comments in paragraph 14.8.**

It should also be noted that since nothing written anywhere in the Rulebook defines terms such as general impression and flying style, accurate and repeatable marking really depends “only” (!) upon each judge deciding on the total number of errors committed and the degree to which each error has deviated from the flight track defined in each maneuver Rule. This **includes** subjective elements, where (apart from stability, which can be marked as discussed in 14.7.), the reality is that each competitor's score should depend “simply” (!) and solely upon the total number of all the errors observed by each judge, coupled with each judges' decision as to the degree of severity of each of those errors.

14.10. Consideration of external factors.

With the exceptions mentioned in Landing (*Rule 13.15.*),

“normal” external factors should not in any way affect the marks awarded by judges. So it is **not** permitted for judges' marks to allow for the effects of gusty winds in marking any phase of any maneuver, **except** during the ground rollout phase of the Landing maneuver—for example, if a sudden fierce gust of wind coming from behind the model aircraft causes it to flip over or tip onto its nose during the last part of the ground rollout.

This therefore means that factors such as wind, turbulence, gusts, and any other factors outside the competitor's control should not normally influence the marks awarded by the judges. However, some individual exceptions to this general observation may occur occasionally—for example, a safety-related exception should be imminent danger of electrocution by thunderstorm. Exceptions should also be made where a completely “accidental” incident prevents the proper execution of a maneuver or forces a competitor to abandon a maneuver or a flight altogether (for example), an animal wandering into the flight circle). In cases where the head judge feels that such external factors have influenced the result of a competition flight, he should use his discretion and authority to recommend that the Contest Director grant a reflight.

14.11. Judging a maneuver missed by a judge. If a judge misses the observation of a maneuver for any reason, he or she should not mark an estimated “typical” mark for the missed maneuver. Instead the judge who missed the maneuver should clearly write an “X” symbol on his/her score sheet in the space for the mark for the maneuver which has been missed. This symbol should then alert the scores tabulating team to use a procedure which calculates the average of the marks for the maneuver as awarded by all the other judges. This calculated average mark should then be entered into the missing mark “X” area by the scores tabulating team before they proceed with further processing of all the remaining marks from that flight.

14.12. Results awareness. In order to prevent influence of any kind, no judge shall look at tabulated results scores and/or at competitors placings until after the completion of a competition. Neither should judges discuss individual official flights, the execution of maneuvers, and/or the marks awarded (and/or the tabulated results and scores), with anyone at all during the whole competition, including other judges, competitors, or team managers. The head judge should ensure that all members of the Judges' Panel observe these requirements throughout the competition.

14.13. Judges' preparations to be made at Competition Sites. Well before the start of official competition flights, the head judge should meet the competition organizer and Event Director to define and/or verify:

14.13.1. Head judge in charge.

14.13.2. Classification procedures.

14.13.3. Score calculation procedures.

14.13.4. Competitors' flying order.

14.13.5. Competitor call-up procedure.

14.13.6. Nominated official timekeeper; how times will be communicated to Judges' Panel.

14.13.7. Duration of rounds.

14.13.8. Meal and break times; seating arrangements; sunshades; umbrellas; etc.

14.13.9. Availability of score recorders.

14.13.10. Score sheet transportation.

14.13.11. Competitors' pull-test procedure.

14.13.12. The availability of fixed terrain reference points, and/or erected markers (refer 14.4.2. and 14.4.3.).

14.14. Judges' calibration ("warm-up")

flights. A minimum of two warm-up flights, to be flown immediately prior to the beginning of official competition flights, should be flown per each round (or per each day) of the contest by volunteer pilots selected by random draw from among all registered competitors. After each warm-up flight the judges should go through a maneuver-by-maneuver discussion, comparing and discussing their individual assessments of each error (including the severity of those errors) that they have seen during every segment of every figure and every maneuver flown. The judges may discuss the individual maneuver scores amongst themselves. The content of all such judges' warm-up flight discussions should not be made public. In particular, the pilots at the contest shall not be advised, notified, or in any way be allowed to participate, in the evaluation of the warm up flights.

14.15. Sighting devices and terrain reference points. Hand-held sighting devices should not be used. Whenever possible, fixed terrain reference points should be used to define intersections, "verticals," line elevation angles, and 1/8 lap (45 degrees laterally) bottom maneuver lengths and/or lap segments. As per 14.4.2. and 14.4.3., contest organizers are also encouraged to erect suitable markers (for example, for the 45 degrees lateral dimension specified in the relevant maneuver Rules), especially when a particular contest site lacks natural fixed reference points. It is recommended that such reference points and/or markers be recalibrated for each individual competition site on the occasion of each competition held at that site, and that these should be discussed privately between the judges prior to the start of warm-up flights. Final agreement on useable natural reference points and/or erected markers should be reached between all members of the Judges' Panel before the start of official competition flights.

14.16. Time-keeping. It is common practice to assign official time-keeping duties to the Stunt Circle Marshall. Before starting official competition flights, judges should confirm that this is indeed the case. Judges should also define the method(s) by which the results of this timekeeping will be signaled to the Judges' Panel. The times recorded by the defined official timekeeper are binding, but as a cross reference it is recommended that the head judge runs his/her own stopwatch in parallel to the official timekeeper (see also 14.37.9.).

14.17. Judges' position. The panel of judges should be placed in a position defined by each competitor prior to starting his/her official flight. Judges may however, at their own discretion, move from the positions originally taken at the start of an official flight

in order to position themselves optimally for the maneuver and account for shifts of the wind, etc. There is no limitation on the degree of movement but in cases where extreme shifts occur it is recognized that it will not be practical to attain perfect positioning. The judges should attempt to make a best effort, within reason and the time for the two laps in between maneuvers.

14.18. Contest supervision. Judges should closely observe the running of the contest in general, and the proceedings on the Stunt flight circle in particular. Where not defined by the organizer, the panel of judges shall name a head judge as its speaker for addressing the Contest Director. The head judge shall intervene in the running of the contest if the goal of fairness appears to be in danger, and the head judge may at all times take safety-related decisions and order suitable remedial action.

14.19. Consistency. Judges should use a consistent scale of awarding marks throughout all the rounds of a competition. This scale should be a personal instrument based upon the number of errors seen, plus the severity of each error. This personal scale should have been arrived at by careful study of the current rules, study of this Judging Instructions document, and as a result of practical judging experience. Once the official flights of a competition have started, each judge's personal scale should remain firm and fixed and should **not** (for example) become influenced by factors such as discussions with others (including other judges), by the weather, by model aircraft speed, by model aircraft type or engine sound, or by an awareness of the reputation or results previously achieved by any particular pilot being judged. In this respect it should be noted that in the following maneuver descriptions the words model aircraft and competitor (and **not** pilot) have been used!

14.20. Definition of an Attempt (Rule 7.).

14.20.1. "*called to the circle*"; means that an official calls the competitor to enter the circle.

14.20.2. "*within three minutes of the starting signal*"; means that the model aircraft does not become airborne within three minutes of giving the starting signal. This leads to a critical point: judges are advised to watch for the competitor (or an official) calling for an attempt if the model aircraft does not become airborne within three minutes from the starting signal.

14.21 Execution of Maneuvers (Rule 11.1. and 11.2.).

14.21.1. Judging "... a minimum of 2 laps."; competitors may choose to fly more than, but may not fly less than, two nominal intervening laps between each maneuver.

14.21.2. Judging the height of intervening laps: the height of the laps flown between maneuvers is not specified in the Rulebook and should therefore not be judged or marked.

14.21.3. Judging incomplete maneuvers: any maneuver which is started but not completed shall be awarded a mark of 0 (zero) points.

14.21.4. Judging omitted maneuvers; every maneuver omitted from the List of Flight Maneuvers (Rule 13.) should be awarded a mark of 0 (zero) points.

14.21.5. Judging maneuvers flown with an incorrect number of multiple figures (for example: the Three Consecutive Inside Loops maneuver required [Rule 13.3]); but the maneuver is actually flown with 2 or 4 loops): All maneuvers flown in such ways are incorrect and shall be awarded a mark of 0 (zero) points.

14.21.6. Attempted maneuver(s); if a competitor makes more than one attempt at any one maneuver during one official flight the judges should mark the first attempt in accordance with the instructions listed in this paragraph and the relevant following maneuver description paragraph. Any further attempt(s) at the same maneuver during the same official flight shall not be marked.

14.22. Duration of Flight (Rule 8.).

14.22.1. Start of timing; the timekeeper and/or judge(s) should start timing when the competitor gives a hand signal indicating that he/she is ready to start the motor(s).

14.23. Take-off (Rule 13.1.).

14.23.1. Start judging at: the beginning of the Take-off ground roll.

14.23.2. Judging the ground roll and lift-off segment; from the beginning of the Take-off ground roll to the point of lift-off.

Lift-off should not occur before 4.5 meters (14.8 feet) from start of ground roll, nor later than 1/4 of a lap. "*Smoothly*" means without a "sudden jump" into the air.

14.23.3. Judging the climb out and leveling-off segment; from lift-off, up to and including leveling-off. Leveling-off should occur at a height of 1.5 meters (4.9 feet), plus/minus 30 cm (1 foot), and should occur exactly overhead the point of the beginning of the Take-off ground roll. "*Gradual*" means that the rate of climb should be constant throughout the climb from lift-off until leveling-off into normal upright level flight. "*Smooth*" means a "jerk-free" transition from climbing flight to level flight.

14.23.4. Judging the level flight segment; two laps, from the end of leveling-off to the end of lap three. "*Smooth laps of normal level flight*" means that the model aircraft does not deviate from a height of 1.5 meters (4.9 feet) plus/minus 30 cm (1 foot).

14.23.5. Stop judging: at the end of lap three, exactly overhead the point of the beginning of the Take-off ground roll.

14.23.6. Critical points: are take-off ground roll shorter than 4.5 meters (14.8 feet) or longer than 1/4 lap; Model aircraft "jumping" into the air. Reaching level flight altitude too quickly. Climb rate not gradual (for example: too shallow at first and then too steep later). Leveling-off before or after passing exactly overhead the point of the beginning of the Take-off ground roll. Not maintaining a level flight height of 1.5 meters (4.9 feet), plus/minus 30 cm (1 foot) throughout upright level flight, lap numbers two and three.

14.24. One Reverse Wingover (Rule 13.2.).

14.24.1. Entry; from normal upright level flight at a height of 1.5 meters (4.9 feet), plus/minus 30 cm (1 foot).

14.24.2. Start judging; at the beginning of the first turn into a "vertical" climb.

14.24.3. Judging turn radii; all turns should be of a tight radius.

14.24.4. Judging the first "vertical" climb and dive segment; from the beginning of the first turn into a "vertical" climb, over the competitor's head, into a "vertical" dive, until the end of the second turn (recovering from the "vertical" dive into inverted level flight). "*Passing directly over the flier's head*" means that the model aircraft should pass through an imaginary line projected at right angles upwards from the center of the ground circle. "*Cutting the ground circle in half*" means that the judges should "mentally project" the start and finish points of the complete line of "vertical" flight downward onto the ground, with the result that these two points are exactly opposite each other on the ground circle if the first "vertical" climb and "vertical" dive segment has been correctly flown.

14.24.5. Judging the inverted "horizontal" level flight segment; after recovery from the first "vertical" dive, until the start of the second turn into the second "vertical" climb. The inverted level flight segment should be flown at a height of 1.5 meters (4.9 feet), plus/minus 30 cm (1 foot). The length of the inverted flight segment, including turns, should be exactly 1/2 a lap.

14.24.6. Judging the second "vertical" climb and dive segment; the point at which the model aircraft first reaches a "vertical" attitude in this second "vertical" climb should be exactly the same as the point at which the model aircraft first reached a "vertical" attitude at the start of the first "vertical" climb. "*Over the center of the circle*" means that the model aircraft should pass through an imaginary line projected upward at right angles from the center of the ground circle. The point where the model aircraft starts its recovery to normal upright level flight at the end of the whole maneuver should be exactly opposite the point where the model aircraft first reached "vertical" flight attitude at the start of the whole maneuver. Recovery should bring the model aircraft to normal upright level flight at a height of 1.5 meters (4.9 feet) plus/minus 30 cm (1 foot).

14.24.7. Stop judging; at the end of the fourth turn (recovery to normal upright level flight).

14.24.8. Critical points are; first climb not "vertical." Model aircraft not passing through the right angled line projected upwards from the center of the flight circle. "Vertical" climb and/or dive segments being curved (meaning not "straight line") flight path(s). Recovery(ies) to inverted level flight and/or to normal upright level flight not at a height of 1.5 meters (4.9 feet), plus/minus 30 cm (1 foot). Not maintaining a height of 1.5 meters (4.9 feet), plus/minus 30 cm (1 foot) during inverted level flight. The "turning points" defined above not being exactly opposite each other. Turn radii not equal in all four turns and/or not of a tight radius.

14.25. Three Consecutive Inside Loops (Rule 13.3.).

14.25.1. Entry; from normal upright level flight at a height of 1.5 meters (4.9 feet), plus/minus 30cm (1 foot).

14.25.2. Start judging; at the start of the first loop (as the model aircraft departs its normal upright level flight path).

14.25.3. Judging the first loop; from normal upright level flight the model aircraft should fly upwards along a circular flight path to a height specified in *Sec. 13.3* as a line elevation angle of 45 degrees, at which point it should be inverted. The model aircraft should continue, without interruption, its circular flight path downwards until reaching its first normal upright level flight height, at which point it should be upright.

“*Round*” means no visible deviations from a circular flight path. “*Smooth*” means without flat spots or “jerks.” When the model aircraft reaches a “vertical” attitude for the first time this has defined the lateral reference for the whole maneuver.

14.25.4. Judging the second and third loops; the model aircraft should follow a flight path exactly as described above. The second and third loops should be flown in exactly the same position (meaning that the second loop should be superimposed exactly on top of the first loop, and the third exactly on top of the second), and all three should be of exactly the same size.

14.25.5. Stop judging; at the end of the third loop as the model aircraft completes recovery into normal upright level flight.

14.25.6. Exit procedure; should be flown as recommended by this rule but should not be judged or marked.

14.25.7. Critical points are; line elevation angle(s) above 45 degrees (loop[s] too big). Line elevation angle(s) less than 45 degrees (loop[s] too small). Bottom(s) of loops not all at a height of 1.5 meters (4.9 feet), plus/minus 30 cm (1 foot). Tops and/or bottoms of loops are not all at the same heights. Shapes are not truly circular. Flight path is not steady (examples: uneven rate of turn; “wobbling” flight). Flat spots on any of the loops. Second and third loops are not exactly the same size as the first. Second and third loops are not in exactly the same position (not superimposed upon) the first loop.

14.26. Two Laps Inverted Flight (*Rule 13.4.*)

14.26.1 Entry; from inverted level flight at a height of 1.5 meters (4.9 feet) plus or minus 30 cm (1foot).

14.26.2. Start judging; at the beginning of lap three (as counted from the exit point of the Three Consecutive Inside Loops maneuver - *Rule 13.3.*)

14.26.3. Judging inverted flight height; should be at 1.5 meters (4.9 feet). “*Stable*” means that the model aircraft does not deviate by more than plus/minus 30 cm (1 foot) from 1.5 meters (4.9 feet). “*Smooth*” means the absence of visible height deviations.

14.26.4. Stop judging; at the end of lap four (as counted from the exit point of the Consecutive Inside Loops maneuver - *Rule 13.3.*)

14.26.5. Critical points are; the first inverted flight height at the beginning of lap three is not 1.5

meters (4.9 feet), plus/minus 30 cm (1 foot). Model aircraft deviates more than plus/minus 30 cm (1 foot) from a height of 1.5 meters (4.9 feet) during the two judged laps. The model aircraft shows visible height corrections.

14.27. Three Consecutive Outside Loops (*Rule 13.5.*)

14.27.1. Entry: from level inverted flight at a height of 1.5 meters (4.9 feet), plus/minus 30 cm (1 foot).

14.27.2. Start judging; at the beginning of the first loop (as the model aircraft departs its level inverted flight path).

14.27.3. Judging the first loop; from level inverted flight the model aircraft should fly upwards along a circular flight path to a height specified in the *Sporting Code* as a line elevation angle of 45 degrees, at which point it should be upright. The model aircraft should continue, without interruption, its circular flight path downward until reaching its first inverted flight height, at which point it should be inverted. “*Round*” means no visible deviations from a circular flight path. “*Smooth*” means without flat spots or “jerks.” When the model aircraft reaches a “vertical” attitude for the first time this has defined the lateral reference for the whole maneuver.

14.27.4. Judging the second and third loops; the model aircraft should fly a flight path exactly as set out in the individual segments above. The second and third loops should be flown in exactly the same position (meaning that the second loop should be superimposed exactly on top of the first loop and the third loop onto the second) and all three should be of exactly the same size.

14.27.5. Stop judging; at the end of the third loop, when the model aircraft passes the 1.5 meters (4.9 feet) normal flight level in inverted flight.

14.27.6. Exit procedure; should be flown as recommended by this rule but should not be judged or marked.

14.27.7. Critical points are; line elevation angle(s) above 45 degrees (loop(s) too big). Line elevation angle(s) less than 45 degrees (loop[s] too small). Bottom of loop(s) not at a height of 1.5 meters (4.9 feet), plus/minus 30 cm (1 foot). Tops and/or bottoms of loop(s) are not all at the same heights. Shapes are not circular. Flight path is not steady (example: “wobbling” or “jerky” flight). Flat spots on any of the loops. Second and third loops are not exactly the same size as the first. Second and third loops are not in exactly the same position (not superimposed upon) the first loop.

14.28. Two Consecutive Inside Square Loops (*Rule 13.6.*)

14.28.1. Entry; from normal upright level flight at a height of 1.5 meters (4.9 feet) plus/minus 30 cm (1 foot).

14.28.2. Start judging; from the point in normal upright level flight where the model aircraft begins its first turn into a “vertical” climb.

14.28.3. Judging turn radii; all turns should be of a tight radius.

14.28.4. Judging the first turn plus “vertical” climbing segment; the model aircraft should reach and maintain a flight path which is nearly at right angles to the ground.

14.28.5. Judging the second turn plus top “horizontal” segment; the model aircraft should turn into inverted level flight to reach a height of 45 degrees line angle elevation as it becomes inverted. The top segment should be flown in inverted level flight with the flight path parallel to the ground.

14.28.6. Judging the third turn plus “vertical” diving segment; the model aircraft should reach and maintain a flight path which is nearly at right angles to the ground.

14.28.7. Judging the fourth turn plus bottom “horizontal” segment; the model aircraft should recover to normal upright level flight at a height of 1.5 meters (4.9 feet) plus/minus 30 cm (1 foot). The length of the bottom segment, including both turns, should be exactly 1/8 of a lap.

14.28.8. Judging the complete second loop; the model aircraft should fly a flight path exactly as set out in the individual segments above. The second loop should be flown in exactly the same position (meaning that the second loop should be superimposed exactly onto the first loop) and should be of exactly the same size as the first loop.

14.28.9. Stop judging; in normal upright level flight, at exactly the point where the model aircraft started its first turn into a “vertical” climb at the beginning of the complete maneuver.

14.28.10. Critical points are; line elevation angle(s) above 45 degrees (loop[s] too big; top segment[s] flown too high). Line elevation angle(s) less than 45 degrees (loop[s] too small; top segment[s] flown too low). Turn radii are not of a tight radius. Top segment(s) not level (not parallel to the ground and/or not “straight line” flight throughout). Bottom segment(s) not at a height of 1.5 meters (4.9 feet), plus/minus 30 cm (1 foot). Length of bottom segment(s) greater than/less than 1/8 of a lap. Loop(s) are either wider than their height(s) and/or higher than their width(s). Sides are not “straight line” flight. Flight path is not steady (example: “wobbling” flight). Second loop is not exactly the same size as the first. Second loop is not in exactly the same position (meaning not superimposed exactly upon) the first loop.

14.29. Two Consecutive Outside Square Loops (Rule 13.7.).

14.29.1. Entry; from upright level flight at a height of 45 degrees line angle elevation.

14.29.2. Start judging; from the point in normal upright level flight where the model aircraft starts its first turn downwards into a “vertical” dive.

14.29.3. Judging turn radii; all turns should be of a tight radius.

14.29.4. Judging the first turn plus “vertical” dive segment; the model aircraft should reach and maintain a flight path which is nearly at right angles to the ground.

14.29.5. Judging the second turn plus bottom “horizontal” segment; the model aircraft should recover from diving flight to inverted level flight at a height of 1.5 meters (4.9 feet) plus/minus 30 cm (1 foot). The bottom segment should be flown with the flight path parallel to the ground. The length of the bottom segment, including both turns, should be 1/8 of a lap.

14.29.6. Judging the third turn and “vertical” climbing segment; the model aircraft should reach and maintain a flight path which is nearly at right angles to the ground.

14.29.7. Judging the fourth turn and top “horizontal” segment; the model aircraft should recover into upright level flight at a height of 45 degrees line angle elevation. The top segment should be flown in level upright flight with the flight path parallel to the ground.

14.29.8. Judging the complete second loop; The model aircraft should fly exactly as set out in the individual segments above. The second loop should be flown in exactly the same position (meaning that the second loop should be superimposed exactly on top of the first loop) and should be of exactly the same size as the first loop.

14.29.9. Stop judging; in level flight, at exactly the point where the model aircraft started its first turn into a “vertical” dive at the beginning of the complete maneuver.

14.29.10. Exit procedure; should be flown as recommended by this rule but should not be judged or marked.

14.29.11. Critical points are; maneuver entry height not within the plus/minus 30 cm (1 foot) tolerance. Model aircraft not in level flight when starting first turn. Line elevation angle(s) above 45 degrees (loop[s] too big; top segment[s] flown too high). Line elevation angle(s) less than 45 degrees (loop[s] too small; top segment[s] flown too low). Turn radii are not equal and/or not of a tight radius. Top segment(s) too high and/or too low (not at 45 degrees line angle elevation). Top segment(s) not level (parallel to the ground; not “straight line” flight throughout). Bottom segment(s) not at a height of 1.5 meters (4.9 feet) plus/minus 30 cm (1 foot). Length of bottom segment(s) greater than/less than 1/8 of a lap. Loop(s) are either wider than their height(s) and/or higher than their width(s). Sides are not “straight line” flight. Flight path is not steady (example: “wobbling” flight). Second loop is not exactly the same size as the first. Second loop is not in exactly the same position (not superimposed exactly upon) the first loop.

14.30. Two Consecutive Inside Triangular Loops (Rule 13.8.).

14.30.1. Entry; from normal upright level flight at a height of 1.5 meters (4.9 feet) plus/minus 30 cm (1 foot).

14.30.2. Start judging; from a point in normal, level flight where the model aircraft starts its first turn into an inverted climb.

14.30.3. Judging turn radii; all turns should be of a tight radius.

14.30.4. Judging the first (climbing) turn plus inverted climb segment: the model aircraft should reach and maintain a “straight line” inverted climb flight path at approximately 30 degrees past right angles to the ground.

14.30.5. Judging the second (diving) turn segment; the model aircraft should turn through approximately 60 degrees, reaching and maintaining a “straight line” inverted dive flight path at approximately 30 degrees less than a right angle to the ground. The maximum height reached during this turn should not exceed a line elevation angle of 45 degrees.

14.30.6. Judging the third turn plus bottom “horizontal” segment: the model aircraft should recover to normal upright level flight at a height of 1.5 meters (4.9 feet) plus/minus 30 cm (1 foot). The length of the bottom segment, including both turns, should be equal to the length of both the climbing and the diving flight segments including their respective turns.

14.30.7. Judging the complete second loop: the model aircraft should fly exactly as set out in the individual segments above. The second loop should be flown in exactly the same position (meaning that the second loop should be superimposed on top of the first loop) and should be of exactly the same size as the first loop.

14.30.8. Stop judging: with the model aircraft in normal level upright flight, at exactly the same point as the model aircraft started its first turn at the start of the complete maneuver.

14.30.9. Critical points are: line elevation angle(s) above 45 degrees (loop[s] too big). Line elevation angle(s) less than 45 degrees (loop[s] too small). Turn radii are not equal, and/or not of a tight radius. Climbing and or diving flight segment(s) not “straight line” flight path(s) and/or flight path(s) not at approximately 60 degrees to the ground. Bottom segment(s) not “straight line” flight, and/or not parallel to the ground, and/or not at a height of 1.5 meters (4.9 feet) plus/minus 30 cm (1 foot). Length of individual segments (meaning sides of triangles) not equal. Tops and/or bottoms of loops are not all at the same heights. Second loop is not exactly the same size as the first. Second loop is not in exactly the same position (not superimposed exactly upon) the first loop.

14.31. Two Horizontal Eights (Rule 13.9.).

14.31.1. Entry: from normal upright level flight at a height of 1.5 meters (4.9 feet) plus/minus 30 cm (1 foot).

14.31.2. Start judging: when the model aircraft passes the intersection point for the first time.

14.31.3. Locating the intersection: when the model aircraft reaches a “vertical” climbing attitude for the first time this has defined the intersection point for the whole maneuver (i.e. after 1/4 of a full loop has been flown).

14.31.4. Judging the first inside loop: from normal upright level flight the model aircraft should fly upwards along a circular flight path to a height specified in the Rulebook as a line elevation angle of 45 degrees, at which point it should be inverted. The model aircraft

should continue, without interruption, its circular flight path downwards until reaching its first normal upright level flight height, at which point it should be upright. The model aircraft should then, without interruption, continue its circular flight path for a further 1/4 of a loop until reaching the intersection point, at which point it should be momentarily “vertical.” This is exactly the same as described for the Inside Loops maneuver (*Rule 13.3.*), and “Round” means no visible deviations from a circular flight path. “Smooth” means without flat spots or “jerks.” The height of the bottom of the first inside loop should be 1.5 meters (4.9 feet) plus/minus 30 cm (1 foot).

14.31.5. Judging passage through the intersection point and transition into the first outside loop: the intersection point first defined by the model aircraft at the beginning of the maneuver (14.31.3. above) should be maintained throughout the complete maneuver. At the time of passing through the intersection point and transitioning to the first outside loop the model aircraft should be momentarily in a “vertical” nose-up attitude but should not visibly travel in a “straight line” and/or along a “vertical” climbing flight path.

14.31.6. Judging the first outside loop (actually one complete loop from the intersection point): after passing through the intersection point the model aircraft should continue, without interruption, to fly a complete outside loop as defined for the Outside Loops maneuver (*Rule 13.5.*). This means that the model aircraft should fly upward along a circular flight path to a height specified in the Rulebook as a line elevation angle of 45 degrees, at which point it should be upright. The model aircraft should continue its circular flight path downwards until reaching the inverted flight height of 1.5 meters (4.9 feet) plus/minus 30 cm (1 foot), at which point it should be inverted. “Round” means no visible deviations from circular. “Smooth” means without flat spots or “jerks.” The model aircraft should then, without interruption, continue its circular flight path for a further 1/4 of a loop until reaching the intersection point, at which point it should be momentarily “vertical.”

14.31.7. Judging the second complete figure eight: the model aircraft should follow a flight path exactly as set out in the individual segments above. The second figure eight should be flown in exactly the same position (meaning that the second eight should be superimposed exactly on top of the first eight) and should be of exactly the same size as the first eight.

14.31.8. Stop judging: as the model aircraft completes the second figure eight, when passing the intersection point in a “vertical” climb for the fifth and last time.

14.31.9. Exit procedure: should be flown as recommended by this rule but should not be judged or marked.

14.31.10. Critical points are: line elevation angle(s) above 45 degrees (eight[s] too big). Line elevation angle(s) less than 45 degrees (eight[s] too small). Bottom(s) of eight(s) not at a height of 1.5 meters (4.9 feet), plus/minus 30 cm (1 foot). Top(s) and/or bottom(s) of eight(s) are not all at the same height.

Shapes are not circular. Model aircraft not “vertical” when passing through the intersection point. Flat spot(s) on any of the eight(s). Model aircraft flies a “straight line” segment when passing through the intersection point. The intersection varies from the point first defined by the model aircraft. Inside and outside loop(s) are too far apart (resulting in an “X-shaped” flight path at the intersection point). The second eight is not exactly the same size as the first. The second eight is not in exactly the same position (not superimposed upon) the first eight.

14.32. Two Square Horizontal Eights (Rule 13.10.).

14.32.1. Entry: from normal upright level flight at a height of 1.5 meters (4.9 feet) plus/minus 30 cm (1foot).

14.32.2. Start judging; with the model aircraft in upright level flight, from the point flight where the model aircraft starts its first turn upward into a “vertical” climb for the first time.

14.32.3. Judging turn radii; all turns should be of a tight radius.

14.32.4. Locating the intersection line; when the model aircraft reaches a “vertical” attitude for the first time this has defined the intersection line for the whole maneuver.

14.32.5. Judging the first climbing turn and “vertical” climbing segment of the first (inside) square loop of the first figure eight; the model aircraft should turn into a “vertical” climb, reaching and maintaining a flight path which is at right angles to the ground.

14.32.6. Judging the second turn and top “horizontal” segment of the first (inside) square loop of the first figure eight; the model aircraft should turn into inverted level flight to reach a height of 45 degrees line angle elevation as it becomes inverted. The top segment should be flown with the flight path parallel to the ground.

14.32.7. Judging the third turn and “vertical” dive segment of the first (inside) square loop of the first figure eight; the model aircraft should turn into a “vertical” dive, reaching and maintaining a flight path which is nearly at right angles to the ground.

14.32.8. Judging the fourth turn and bottom “horizontal” segment of the first (inside) square loop of the first figure eight; the model aircraft should recover to normal upright level flight at a height of 1.5 meters (4.9 feet) plus/minus 30 cm (1 foot). The length of the bottom segment, including both turns, should be exactly 1/8 of a lap.

14.32.9. Judging the first climbing turn and “vertical” climb segment of the second (outside) square loop of the first figure eight: at the end of the previous segment (14.32.8.), the model aircraft should turn into a “vertical” climb, reaching and maintaining a flight path which is at right angles to the ground. This flight path should be in exactly the same position as defined by the model aircraft at the beginning of the maneuver (14.32.4.).

14.32.10. Judging the second turn and top “horizontal” segment of the second (outside) square loop

of the first figure eight; the model aircraft should turn into upright level flight to reach a height of 45 degrees line angle elevation as it becomes level. The top segment should be flown with the flight path parallel to the ground.

14.32.11. Judging the third turn “vertical” dive segment of the second (outside) square loop of the first figure eight; the model aircraft should turn into a “vertical” dive, reaching and maintaining a flight path which is nearly at right angles to the ground.

14.32.12. Judging the fourth turn and bottom “horizontal” segment of the second (outside) square loop of the first figure eight; the model aircraft should recover to inverted level flight at a height of 1.5 meters (4.9 feet) plus/minus 30 cm (1 foot). The length of the bottom segment, including both turns, should be exactly 1/8 of a lap.

14.32.13. Judging the complete second figure eight; the model aircraft should follow a flight path exactly as set out in the individual segments above. The second figure eight should be flown in exactly the same position (meaning that the second eight should be superimposed exactly on top of the first eight) and should be of exactly the same size as the first eight.

14.32.14. Judging the last turn and “vertical” climb exit from the maneuver; at the end of the second bottom “horizontal” segment of the fourth loop the model aircraft should turn into a “vertical” climb, reaching and maintaining a flight path which is at right angles to the ground. This flight path should be in exactly the same position as defined by the model aircraft at the beginning of the maneuver (14.32.4.).

14.32.15. Stop judging; as the model aircraft completes the second figure eight, when passing a height of 45 degrees line elevation in a “vertical” climb for the last time.

14.32.16. Exit procedure; should be flown as recommended by this rule but should not be judged or marked.

14.32.17. Critical points are; line elevation angle(s) above 45 degrees (eight[s] too big). Line elevation angle(s) less than 45 degrees (eight[s] too small). Bottom of eight(s) not at a height of 1.5 meters (4.9 feet) plus/minus 30 cm (1 foot). Tops of eight(s) are not all at the same heights. Turn radii are not equal, and/or are not of a tight radius. Bottom segment(s) are not equal, and/or are longer or shorter than 1/8 lap. Bottom segment(s) are not flown parallel to the ground, and/or are not flown at a height of 1.5 meters (4.9 feet) plus/minus 30 cm (1 foot). “Vertical” climb segment(s) are not flown at right angles to the ground. Figure(s) are wider than their height(s). Figure(s) are higher than their width(s). Side(s) of figures are not “straight line” flight path(s), and/or the model aircraft “wobbles.” The intersection line first defined by the model aircraft varies in subsequent segments of the maneuver. The second eight is not exactly the same size as the first. The second eight is not in exactly the same position (not superimposed upon) the first eight.

14.33. Two Vertical Eights (Rule 13.11.).

14.33.1. Entry; from normal upright level flight the model aircraft should fly upward along a circular flight path to a height specified as a line elevation angle of 45 degrees, at which point it should be inverted.

14.33.2. Start judging at; after the model aircraft has flown the first half of an inside loop as it passes through the intersection point for the first time.

14.33.3. Locating the intersection; the intersection of the whole maneuver is defined when the model aircraft passes through inverted level flight at a height of 45 degrees line elevation angle for the first time.

14.33.4. Judging the first segment (inside loop): as the model aircraft passes through the intersection point for the first time it should continue to fly a complete round inside loop. The bottom of this loop should be at a height 1.5 meters (4.9 feet) plus/minus 30 cm (1 foot). The loop should be completed by the model aircraft returning to the inverted position at a height of 45 degrees line elevation angle. "Round" means no visible deviations from a circular flight path.

14.33.5. Judging the model aircraft's passage through the intersection point and transition to the second (outside) loop; the flight path should touch the intersection point and this point should be maintained throughout the entire maneuver. At the time of passing through the intersection point and transitioning into the second (outside) loop, the model aircraft should momentarily be in a level inverted flight attitude but should not visibly follow a "straight line" flight path. Also, the model aircraft should neither climb nor dive during this momentary period of inverted flight.

14.33.6. Judging the second segment (outside loop); as it passes through the intersection point the model aircraft should continue without interruption, flying a complete outside round loop. The bottom of this second loop should be at a height of 45 degrees line elevation angle and the top should be at 90 degree line elevation. "Round" means no visible deviations from a circular flight path.

14.33.7. Locating the "vertical" axis; the centers of both loops should be positioned on an imaginary line drawn upward from the ground at right angles.

14.33.8. Judging the complete second figure eight; the model aircraft should follow a flight path exactly as set out in the individual segments above. The second figure eight should be flown in exactly the same position (meaning that the second eight should be superimposed exactly on top of the first eight) and should be of exactly the same size as the first eight.

14.33.9. Stop judging; as the model aircraft completes the second figure eight, at the moment when it reaches inverted level flight at a height of 45 degrees line elevation angle.

14.33.10. Exit procedure; should be flown as recommended by this rule but should not be judged or marked.

14.33.11. Critical points are; the lower (inside) loop(s) are too big with line elevation angle(s) exceeding 45 degrees. The upper (outside) loop(s) are too big/too small with line elevation angle(s) not reaching or

exceeding 1.2 meters (4 feet) from 90 degrees line elevation. Bottom(s) of lower loop(s) not at a height of 1.5 meters (4.9 feet) plus/minus 30 cm (1 foot). The intersection point is not at a height of 45 degrees line elevation angle, plus/minus 30 cm (1 foot). All loops are not of the same size. The loops are not round. The loops show flat spots. The model aircraft is not momentarily parallel to the ground when passing through the intersection point. The model aircraft follows a climbing and/or diving flight path when passing through the intersection point. Loops overlap. The intersection flight path is "S"-shaped. The loops are too far apart. The intersection point flight path is "X"-shaped. The intersection point varies from the position first defined by the model aircraft during the first inside loop. Loops are not all positioned on the "vertical" axis (13.33.3.). The second eight is not exactly the same size as the first. The second eight is not in exactly the same position (not superimposed upon) the first eight.

14.34. One Hourglass Figure (Rule 13.12.).

14.34.1. Entry; from normal upright level flight at a height of 1.5 meters (4.9 feet) plus/minus 30 cm (1 foot).

14.34.2. Start judging; with the model aircraft in upright level flight, from the point where the model aircraft starts its first turn into a climb for the first time.

14.34.3. Judging turn radii; all turns should be if a tight radius.

14.34.4. Judging the first turn and inverted climb segment; the model aircraft should reach and maintain an inverted climb with a "straight line" flight path angled at approximately 30 degrees past right angles to the ground. That climb should be continued until terminated with an outside turn which should result in the model aircraft following a wingover path. That wingover path should be located at 90 degrees to the center line axis of the whole maneuver.

14.34.5. Judging the "overhead" segment and third turn; this segment should be flown in "straight line" flight and the length of this segment, including its two turns, should be slightly more than 1/8 lap. This segment should be finished by an outside turn through approximately 60 degrees into an inverted dive.

14.34.6. Judging the inverted dive segment; the model aircraft should reach and maintain an inverted dive with a "straight line" flight path angled at approximately 60 degrees to the ground.

14.34.7. Judging the intersection; the intersection of the two climbing/diving segments should be at a height of 45 degrees line elevation angle.

14.34.8. Judging the maneuver's symmetry; the figure should be flown symmetrically in relation to its "vertical" center axis.

14.34.9. Judging the fourth turn and bottom level flight segment; the model aircraft should recover to normal upright level flight at a height of 1.5 meters (4.9 feet) plus/minus 30 cm (1 foot). The length of this segment should be slightly more than 1/8 of a lap.

14.34.10. Stop judging; with the model aircraft in normal level upright flight, at exactly the same point

as the model aircraft started its first turn at the start of the complete maneuver.

14.34.11. Critical points are; corner angles are significantly different from 60 degrees. Turn radii are not equal and/or are not of a tight radius. Climb and/or dive segments are not “straight line” flight path(s.) When passing the overhead point, the line elevation angle does not reach (or it exceeds) 90 degrees within 60 cm. The top and bottom segments are twisted in relation to each other. The height of the bottom segment is not at 1.5 meters (4.9 feet) plus/minus 30 cm (1 foot). The bottom segment is not flown parallel to the ground throughout. The intersection point is not at a height of 45 degrees line elevation angle. Climbing and/or diving segment flight path angles are not the same and/or produce an asymmetric maneuver.

14.35. Two Overhead Figure Eights (Rule 13.13.).

14.35.1. Entry; from normal upright level flight the model aircraft should climb to the overhead point.

14.35.2. Start judging; as the model aircraft passes through the overhead point for the first time.

14.35.3. Locating the overhead/intersection point: the overhead point and the intersection point should be in exactly the same position—that is; at the point where the top of the flying hemisphere meets an imaginary line projected upward at right angles from the center of the ground circle.

14.35.4. Judging the first segment (complete inside loop): from the overhead position, the model aircraft should fly a complete round inside loop, returning to the overhead/intersection point. The bottom of this loop should be at a height of 45 degrees line elevation angle plus/minus 30 cm (1 foot). “Round” means with no visible deviation from a circular flight path. This loop should be flown symmetrically to an imaginary line on the face of the flying hemisphere drawn upward at 90 degrees to the axis of the model aircraft’s climb to the intersection point.

14.35.5. Judging passage through the intersection point and transition into the second (outside) loop segment; the intersection point should be maintained throughout the entire figure eight. At the time of passing through the intersection/overhead point, the model aircraft should smoothly transition into the second (outside) loop without visibly following either a “straight line” and/or a curved flight path. As it flies overhead the center of the ground circle, the model aircraft should be momentarily in a “knife edge” position with a line elevation angle of 90 degrees.

14.35.6. Judging the second segment (complete outside loop); from the overhead position, the model aircraft should transition smoothly into the second round (outside) loop, returning to the overhead/ intersection point. The bottom of this loop should be at a height of 45 degrees line elevation angle plus/minus 30 cm (1 foot). “Round” means no visible deviation from a circular flight path. This loop should also be flown symmetrically to an imaginary line on the surface of the flying hemisphere drawn upwards at 90 degrees to the axis of

the model aircraft’s climb to the intersection point (14.35.4.).

14.35.7. Judging the second figure eight; the model aircraft should fly exactly as set out in the individual segments above. The second eight should be flown in exactly the same position (meaning that the second eight should be superimposed on top of the first eight) and should be of exactly the same size as the first eight.

14.35.8. Stop judging; at the end of the second (outside) loop as the model aircraft passes through the intersection point.

14.35.9. Exit procedure; should be flown as recommended by this rule but should not be judged or marked.

14.35.10. Critical points are; model aircraft is not vertically overhead (90 degrees line angle) at the time of entry into the maneuver. Loops are too big with bottoms reaching down below 45 degrees line elevation angle. Maneuver shows left/right 45 degrees line elevation angle asymmetry. Maneuver shows front/rear asymmetry. Maneuver orientation is “twisted” in relation the “vertical” entry center line axis. Loop(s) are not same size. Loops are not round. Model aircraft is not 90 degrees overhead when passing through the intersection point. Model aircraft curves left/right when passing through the intersection point. The intersection point varies from its initial position as defined by the entry point. The second eight is not superimposed exactly on top of the first.

14.36. One Four-leaf Clover (Rule 13.14.).

14.36.1. Entry; “... level flight at approximately 42 degrees elevation” means that the model aircraft should be in upright level flight at a height of 42 degrees line elevation height before starting the first (inside) loop.

14.36.2. Start judging; with the model aircraft in upright level flight at a height of 42 degrees line elevation angle, just before the point of entry into the first (inside) loop.

14.36.3. Judging the complete first (inside) full loop figure; “full inside loop” means a full 360-degree circle which is positioned tangentially to an imaginary “vertical” line drawn upward at right angles from the ground. The lateral position of this line is determined when the model aircraft reaches a “vertical” attitude for the first time and this imaginary line then becomes the lateral reference for the whole maneuver. The top of the first loop should be tangential to the wingover path located at 90 degrees to the center line axis of the whole maneuver. The model aircraft should recover into upright level flight at a height of 42 degrees line elevation angle plus/minus 30 cm (1 foot). “Round” means with no visible deviations from a circular flight path.

14.36.4. Judging upright level flight at 42 degrees line elevation angle; at 42 degrees line elevation angle the model aircraft should follow a “straight line” flight path parallel to the ground in upright level flight. The length of this segment should be equal to the diameter of the first (inside) loop.

14.36.5. Judging the second (outside) 3/4- loop segment; "... *three-fourths of an outside loop*" means an arc measuring 270 degrees. The 270 degrees of this loop should be flown as a true circular arc without visible deviations from a circular flight path. The bottom of this loop should be at a height of 1.5 meters (4.9 feet) plus/minus 30 cm (1 foot) and this loop should end with the model aircraft entering "vertical" climb whose flight path is the same as the great circle line resulting from flying the first loop.

14.36.6. Judging the first "vertical" climb segment; the model aircraft should climb vertically (at right angles to ground) and the length of this segment should be equal to the diameter of the first inside loop.

14.36.7. Judging the third (outside) 3/4-loop segment; "*three-fourths of an outside loop*" means an arc measuring 270 degrees. The 270 degrees of this loop should be flown as a true circular arc without visible deviations from a circular flight path. The bottom of this loop should be at a height of 42 degrees line elevation. The loop should end with the model aircraft recovering to inverted level flight at a height of 42 degrees line elevation angle plus/minus 30 cm (1 foot).

14.36.8. Judging inverted level flight at 42 degrees line elevation angle; at 42 degrees line elevation angle the model aircraft should follow a "straight line" flight path parallel to the ground in inverted level flight. The length of this segment should be equal to the diameter of the first (inside) loop.

14.36.9. Judging the fourth (inside) 3/4-loop segment; "... *three fourths of an inside loop*" means an arc measuring 270 degrees. The 270 degrees of this loop should be flown as a true circular arc without visible deviations from a circular flight path. The bottom of this loop should be at a height of 1.5 meters (4.9 feet) plus/minus 30 cm (1 foot) and this loop should end with the model aircraft entering "vertical" climb whose flight path is the same as the great circle line resulting from flying the first loop (14.36.3.).

14.36.10. Judging the second "vertical" climb segment; the model aircraft should climb vertically (at right angles to ground) and the length of this segment should be such that the model aircraft flies through the complete clover leaf figure.

14.36.11. Stop judging; at the end of the last "vertical" climb as the model aircraft passes through a point exactly at right angles to the center of the ground circle.

14.36.12. Exit procedure; should be flown as recommended by this rule but should not be judged or marked.

14.36.13. Critical points are; model aircraft is not flying level at a height of 42 degrees line elevation angle plus/minus 30 cm (1 foot) at the time of entering the figure. The top of the first inside loop does not meet tangentially, or overshoots the wingover path. The model aircraft recovers at a height other than 42 degrees of line angle elevation. The model aircraft climbs or descends during any level flight segments. The 42 degrees angle of line elevation level flight segments are too short or too long. The bottom of the second (outside) loop is not at a

height of 1.5 meters (4.9 feet) plus/minus 30 cm (1 foot). The first "vertical" climb is not at a right angle to the ground. The first "vertical" climb is not tangential to the imaginary "vertical" line defined by the first loop. The top of the third (outside) loop does not meet tangentially, or overshoots the wingover path. The model aircraft recovers into inverted level flight at height other than 42 degrees of line angle elevation. The bottom of the fourth (inside) loop is not at the same height as the bottom of the second (outside) loop. The "horizontal" and "vertical" flight segments are not superimposed one on top of the other. Loops are not of the same size. Loops are not round. The figure is not symmetrical in both axis. The final "vertical" climb is not at right angles to the ground.

14.37. Landing (Rule 13.15.).

14.37.1. Entry: when model starts descent from level flight.

14.37.2. Start judging; when the model aircraft leaves the descent entry height at the beginning of its engine-out landing approach (glide).

14.37.3. Judging the descent segment; "*descends smoothly*" means that during the glide the model does not deviate from a smooth descent.

14.37.4. Judging the touchdown segment; "... *with no bounce or unusual roughness*" means that the model aircraft gently touches down once only and then remains with its entire main wheel in contact with the ground throughout the entire ground rollout. **14.37.5.** Judging the ground rollout segment; the model aircraft should come to a stop within one lap of the touchdown point.

14.37.6. Additional factors for judges consideration; "*Unusual circumstances outside of the pilot's control*" are either ground-surface conditions or obstacles which suddenly appear to be apparently in the approach and landing path. The appearance of such obstacles could lead to the competitor making sudden, unplanned, and/or unspecified maneuvers for safety reasons and should therefore not be penalized by the judges. Similarly, a rough ground surface could cause a model aircraft to bounce on landing without the competitor being able to control the bounce so again rough ground at a contest site should not be penalized by the judges. But with the exception of safety hazards such as an impending thunderstorm, weather conditions generally, and wind conditions especially, should **not** to be considered as "*unusual circumstances outside of the pilot's control.*" Wind and weather should not therefore be considered by judges when awarding marks for the Landing, **except** during the last phase when, as stated at 14.10. as an example, a sudden gust of wind coming from behind the model aircraft could cause it to flip over or tip onto its nose during the ground rollout, but with the competitor powerless to prevent the resulting "crash landing."

14.37.7. Stop judging when the model aircraft ceases the ground roll which is clearly in a forward direction and in line with its normal flight path.

14.37.8. Stop timing when the model aircraft has come to a complete stop at the end of its ground rollout.

14.37.9. Awarding marks for “irregular” landings; the Mark 0 (zero) points should be awarded for the complete landing maneuver if the model aircraft crashes; if it lands on its belly; or if it lands upside-down. The Mark 0 (zero) points should also be awarded if the model aircraft flips over, but this example is subject to the notes at 14.37.6. The Mark 0 (zero) points should also be awarded for the complete Landing maneuver if the official timekeeper confirms that the model aircraft has come to a stop after the total time allowed has elapsed (Rule 8.).

14.37.10. Critical points are; the model aircraft does not fly level at the beginning of the final descent. The model deviates from a smooth descent. The model aircraft touches down on its tail or nose wheel(s) before the main wheel(s) touch. The touchdown is not gentle, and/or there are multiple main wheel touchdowns. The ground rollout is longer than one lap.

14.37.11. Additional remark; it is recommended that one member of the Judges’ Panel makes a note of the total elapsed time on the score sheet of each competitor.

SKILL CLASS PRECISION AEROBATICS

For events 323, 324, 325, 326.

1. Applicability. All pertinent AMA regulations (see sections titled Sanctioned Competition, Records, Selection of Champions, and General), the General Control Line rules and the CL Aerobatics rules shall apply, except as specified below. Any deviations should be clearly spelled out in contest advertisements.

2. Skill Class Precision Aerobatics Classes. This event will be divided into four (4) classes. Distinction between classes should be based roughly on a contestant’s scoring in a previous season (except Beginner). They shall be (in order of increasing skill proficiency:

2.1. Beginner—Abbreviated pattern (The following classes are for pilots who can execute the entire CL Precision Aerobatics pattern as described in the Flight Maneuver section of the CL Precision Aerobatics event.)

2.2. Intermediate—Average score is 300 to 399

2.3. Advanced—Average score is 400 to 499

2.4. Expert—Average score is 500 and up

3. Contestant Classification.

3.1. Beginner. The Beginner skill class for pilots who cannot execute the entire AMA CL Precision Aerobatics pattern as listed in the Maneuver section of the CL Precision Aerobatics event.

3.2. Intermediate, Advanced, and Expert. At a contestant’s first contest, he/she may enter any class at his/her option; however, once committed to a class may only move to a class of higher skill proficiency. Exception: A contestant may move to lower class with

written permission of a Contest Director familiar with CL Precision Aerobatics. CDs should exercise great care before allowing a contestant to move to a lower skill class. A contestant may fly in a higher skill class at a contest in which her/her class is not being flown without permanent commitment to the higher class. Any limitations or combinations of classes should be clearly stated in contest announcements. Advancement is voluntary except as noted below.

4. Skill Class Challenges. It is the responsibility of the Contest Director to settle any disputes over the placing of a competitor in a particular skill class. The CD has the authority to change the skill class of a competitor to higher or lower classes if, in his/her opinion, that competitor is placed in the wrong class; however, the CD should use extreme care in doing so. This is to prevent a competitor from picking a skill class lower or higher than his/her ability just to win a “cheap trophy.” Protests by a competitor over a change in his/her skill class should be made to the Contest Director and only the CD shall have final ruling on the skill class placement.

5. Beginner Class.

5.1. Maneuvers. Maneuver descriptions are the same as listed in the Maneuver section of the CL Precision Aerobatics event except as illustrated at the end of this section. See sample score sheet at the end of this section.

A Beginner flight becomes official when the aircraft becomes airborne except that the pilot may call off the flight at any time prior to making the initial climb of the wingover. Any flight that is called off prior to the

Control Line Precision Aerobatics			
	Maneuver	Points	Score
1	Takeoff and Level Flight	10-40	
2	Wing Over (not reverse)	10-40	
3	Three Inside Loops	10-40	
4	Three Outside Loops	10-40	
5	Two Inside Square Loops	10-40	
6	Two Horizontal Eights	10-40	
7	Two Overhead Eights	10-40	
8	Landing	10-40	
Total			

Flight No. ____ Circle No. ____ Judge _____

Name _____ AMA No. _____

wingover will be recorded as an attempt. The method of the call off signal to the judges will be determined before flights begin.

5.1.1. Takeoff and level flight 10–40

5.1.2. Wingover (not reverse) 10–40

5.1.3. Three inside loops 10–40

(recover right side up or inverted)

5.1.4. Three outside loops* 10–40

(recover right side up)

5.1.5. Two inside square loops 10–40

5.1.6. Two horizontal eights 10–40

5.1.7. Two overhead eights 10–40

5.1.8. Landing 0–40

5.1.9. Flight Pattern Points 0 or 25

*May be entered from upright flight with the maneuver starting at the 45 degree elevation; or by executing a half loop into inverted flight and entering the maneuver from level flight elevation; or by exiting the inside loops inverted and staying inverted two (2) laps (minimum) until the outside loops can be started.

5.2. It is recommended that this pattern be used for all contests providing the Beginner skill class event. This is to promote national uniformity, provide a solid base for learning the full AMA pattern, and attract new people to the event.

5.3. BOM Rule and Appearance Points. The builder-of-the-model rule will not apply to the Beginner class and no appearance points will be awarded.

6. Intermediate Class.

6.1. Maneuvers. See the Maneuver section of the CL Precision Aerobatics event.

6.2. BOM Rule and Appearance Points. The contestant need not be the builder of the model to compete; however, no appearance points will be awarded to the contestant who does not build and finish his/her own model. For contestants who do build and finish their own models, appearance points will be awarded per the Appearance section of the CL Precision Aerobatics event.

6.3. Flight Pattern. See the Flight Pattern section of the CL Precision Aerobatics event.

7. Advanced Class

7.1. Maneuvers. See the Maneuver section of the CL Precision Aerobatics event.

7.2. BOM Rule and Appearance Points. The contestant need not be the builder of the model to compete; however, no appearance points will be awarded to the contestant who does not build and finish his/her own model. For contestants who do build and finish their own models, appearance points will be awarded per the Appearance section of the CL Precision Aerobatics event.

7.3 Flight Pattern. See the Flight Pattern section of the CL Precision Aerobatics event.

8. Expert Class.

8.1. Maneuvers. See the Maneuver section of the CL Precision Aerobatics event.

8.2. BOM Rule and Appearance Points. The contestant need not be the builder of the model to compete; however, no appearance points will be awarded to the contestant who does not build and finish his/her own model. For contestants who do build and finish their own models, appearance points will be awarded per the Appearance section of the CL Precision Aerobatics event.

8.3 Flight Pattern. See the Flight Pattern section of the CL Precision Aerobatics event.

9. Scoring of Incomplete and Unattempted

Maneuvers. If a pilot starts but does not complete a maneuver for any reason, the minimum award given is zero (0) for landing and ten (10) for all others. Unattempted maneuvers will receive no score (0).