

NATIONAL NEWSLETTER

Academy of Model Aeronautics

March 2005



5161 East Memorial Drive Muncie IN 47302
Tel.: (765) 287-1256 Fax: (765) 289-4248
www.modelaircraft.org

In this issue

Two ways to become a better flier	pg. 1
Stabilitor-controlled Stunt model	pg. 2
Double-edged razor blade comeback	pg. 3
Watch out for troublesome ticks	pg. 3
Word search	pg. 4
Spring checklist	pg. 4
Keep track of your hobby	pg. 5
Perfecting the square loop	pg. 5
Fab five of model set up	pg. 6
Recipe: One model airplane club	pg. 6
Inexpensive wheel brakes	pg. 7
Build a balance stand	pg. 7
Notes from an e-flier	pg. 8
Hints and tips	pg. 9

About the National Newsletter:

The *National Newsletter* is edited and published bimonthly at AMA Headquarters

Editor
Jessica Booth

Technical Editor
Ed McCollough

Circulation:
AMA Chartered Club Newsletter Editors
The Model Press
Past Presidents
AMA Executive Council
Associate Vice Presidents
Special Interest Groups
Industry Associates

Articles reprinted in the *AMA National Newsletter* from other sources do not necessarily reflect the opinion of the Academy nor are these articles intended to be endorsements of particular products or opinions by the Academy. Every effort is made to ensure that the information contained herein is accurate, but the Academy of Model Aeronautics is not responsible for errors or omissions. No responsibility is assumed, expressed, or implied as to suitability, safety, or approval of ANY material in this newsletter. Any party using ANYTHING expressed herein does so at his or her own risk and discretion without recourse against anyone. Contributions to the *National Newsletter* are welcome! Credit will be noted and given when due. The Academy reserves the right to edit or reject any material submitted for publication. Permission is granted for quoting or reprinting items contained herein, provided attributes accompany the piece.

from the Clarence Sailplane Society, Glenwood NY

Two ways to become a better flier

by Marty Timm, editor

I don't know about others, but I know I have the most fun when I'm comfortable with what I'm doing and not worrying about picking up the pieces from a mistake that could have been avoided. I am reminded of an old joke about a visitor to New York City who asks a local, "How do you get to Carnegie Hall?" to which the local responds, "Practice, practice, practice."

While "practice" is well and good, it helps to have some objectives to aim for. I have found two things that have helped increase my skill and my enjoyment of the hobby. They are the League of Silent Flight (LSF) and competition. The LSF is a self-paced program that gives RC sailplane pilots simple, achievable goals to shoot for as they improve their piloting skills. Those who participate in LSF are likely to become better pilots, and will find that they enjoy flying more.

The other thing that has helped me is participating in competitions. Now this is where a lot of readers are going to skip to the next article, but I hope some will read on and discover one of the keys to my enjoyment of the hobby.

Gordy Stahl posted the following text in RC Soaring Exchange. I think it sums up what the attraction to competition is for those of us who partake in that venue. Give it a read, and ask yourself if you might be missing out on something good.

Editor's note: The remainder of this article was written by Gordy Stahl.
"For years I used the argument 'I don't like competition flying because I just want to fly sailplanes, I'm in it for the fun.'

I'd go out and fly around hoping not to land in trees or hit something

during the landing. Once in a while I'd hook into some no-brainer lift and put in, what seemed like, hours per flight.

I thought I was pretty good at "getting my sailplane way up high," so I attended a sailplane contest. I had no clue about winch launching, what the tasks were, or that I would be expected to put the nose [of my airplane] down in a specific landing zone — right on time.

I attempted to get some help or some information about how to do the tasks, but everyone was pretty busy getting their equipment ready to fly themselves. To me, it seemed like they weren't very friendly.

I gave it a try anyway and really thought I'd be in the winners circle because I was one hot glow power flier (for real). When I ended the first flight with a pop-off and a one-minute time in a five-minute round — completely missing the landing area — it became pretty clear that my skills didn't extend into the competitive soaring world.

That competition set the tone for the next 10 years of my RC soaring experience. I'd still go out occasionally and put up whatever sailplane I picked up cheap at a swap meet. I would usually end up wrecking it on launch or during landings, but I was having fun.

When I moved to Louisville, Kentucky the sailplane club met every Thursday and Sunday with winch and retriever. Most of the guys were involved in contest Soaring and were excellent pilots. I could not understand what the attraction was to competition!

I mean, on Thursdays and Sundays, we'd spend all day in the clouds on just a few launches, with

see **BETTER FLIER** page 2

very little time waiting around on the ground. There was no stress to compete, just float around all day. However, I quickly noticed that they all were launching less than I was. I would go up to where they were going, but I would end up having to land. They landed their models near them, but I was always walking for my airplane.

But no way was I going to get involved in the rat-race of competition.

I had all the reasons why I wasn't going to get involved—busy that weekend, not interested, don't care what some other guy is doing, I'm just a sport flier, I just enjoy being out—you've heard them all.

Another thing I noticed was the guys would go off together to contests and come back kidding and laughing about the results and the fun they

had. By not being involved in contests, I was shutting myself off from my friends and their shared experiences, but I didn't want to compete because I knew I couldn't do the tasks. I hadn't practiced the tasks, and I wasn't prepared. I knew I would be uncomfortable there, and that wasn't fun—especially knowing I would be beaten. You see, if you can do the tasks, you win, and all I had been doing was having fun.

That part I was starting to get, but I had one thing way wrong about contest flying. In soaring it's not possible to be beaten. There is no way in competition soaring can you ever be beaten; you can only do the task or not. Other pilots have no affect on our success or failure.

At a contest, we show up as if we are going to work. The boss says get five 10-minute flights, make all the landings perfectly, and you will be rewarded. The rest will be paid in the form of having a day of soaring, and

an opportunity to measure their learned and practiced skills against others flying that day.

If the assignment is MOM, you get to test your learned and practiced skills in a more precise comparative situation.

It is definitely possible for someone who has studied and practiced his hobby more than I, to end the day with results closer to what the boss assigned, but no one can beat you in soaring (well maybe in Combat).

Task flying is what every one of our models was created to do. Not one thermal duration ship was ever created to just go out and soar around. While they all can do that, they really come alive when put into a task format. They show their strengths and expose their (or their pilot's) weaknesses.

When I hear that old tome about competition soaring, I think back to Shakespeare and me, "I think thou doth protest too much."

from the Northern Virginia Control Line Association, Falls Church VA

Stabilator-controlled Stunt model; T-tail a sure bet

by Tom McClain, editor

Back in the early 50s, Bob Dailey, the inventor of the I-beam Stunt model, built CL Stabilator-controlled stunt airplanes. He said that his Stabilator-controlled ships were his best.

Rod Pharis learned from Bob Dailey, and built a CL I-beam Stunter named Jupiter with a full-flying horizontal tail. After much experimentation, Rod got it working and flew it in competition. He told me it would turn on a dime. Rod, who lives in Southern California, also helped me design my own Stabilator-controlled Stunt model. I got mine to work—and work well.

Some say the high tail increases the risk of having the wing blank out the airflow over the tail causing pitch instability at high angles of attack. Not so for a CL Stunt model. We do not fly at the slow-high angle of attack speeds that cause this problem.

How do I know? I built one and flew it at the 2001 Brodak and Philly

Phylers contests. My airplane is a semi-scale rendition of Darryl Greenamyre's NF-104 Starfighter of the late 70s. I always loved the Starfighter, and Darryl's paint scheme was striking.

I followed Al Rabe's method to get the fuselage profile. I made a clear transparency and projected it onto the wall over the plans of the Blue Box Gieseke Nobler. This helped me get the moments, engine placement, wing, and tail correct.

Construction techniques and materials were the same as most Stunt airplane. I used a D-tube wing, and a hollowed out, sheeted profile fuselage. It was strengthened with a Warren truss inside. The wing, horizontal tail, and main gear are all removable on this take-apart model. It is covered with silkspan, and filled with clear dope.

How well does it fly? I like it, but don't take my word for it. John Sunderland has flown it, Windy Urtnowski videotaped it and both

BY THE NUMBERS F-104 Red Baron Starfighter

Weight: 52 oz.

Engine: Big Art O.S. 40 FP

Wingspan: 53 inches

Propeller: Bolly 10.5 x 6.25 CF 3-Blade

Airfoil: Gieseke Nobler

Average chord: 11.5 inches

Elev/Flap hinge lines: 14 inches

Flap/CG line: 7 inches

CG to wing leading edge: 3 inches

LE to Spinner back plate: 11 inches

Flap to elevator ratio: 2-3

remarked on how well it flies the pattern. Two members of the Northern Virginia Control Line club have flown it—Jerry Raimo and Clayton Berry—and they like it too. So go for the T-tail, just make sure your linkages are linear and have minimal play.

from the Southern California Ignition Flyers, Glendale CA

Double-edged razor blade makes a comeback with some modelers

Mike Myers, editor

My mother grew up on a ranch in Oklahoma in the 1920s where she really did have to ride a pony 10 miles to school each day. I was born in 1943, and growing up in the fortunate 50s, I frequently heard how hard times were in the 20s and 30s (some days there was a blizzard in the morning and a tornado in the afternoon, and that pony had a rotten, gait etc).

I got some of the same sort of stories from my fellow Southern California Ignition Flyers who were kids in the 30s (we had to cut balsa with broken razor blades snapped to a point, and melt down toothbrush handles with acetone to get glue etc). *Technical Editor's Note: Celluloid toothbrush handles dissolved (not melted) in acetone made a reasonably good model glue. Now, because they are antique, it would not be feasible to use the old handles but, with practice, you could tailor the glue to the job.*

I treated it all, whether it came from my mother or my fellow modelers, with a gain of salt—or more likely a pound of salt. Guys I know would tell me how hard they had it (and they did), but I sort of pooh-pooed the whole deal. After all, they had taught me to use surgical scalpels to cut balsa a dozen years ago, so I figured razor blades were passé for model building.

It's true I use the single-edge razor blade—you can buy them in a box of 100 at the hardware store. They're okay for trimming tissue or silk edges when you're covering—they dull quickly, but what the heck, they're cheap. The blades cost roughly 6 cents each, and if you have to use half a dozen to cover a model—so what.

Well, my eyes were opened recently. Tim Goldstein out in Denver sells a lot of things for indoor modeling. He also had some packs of 100 old-fashioned, carbon steel, double-edge razor blades for sale.

I bought some a couple of years ago, and put them near my workbench and left them there unopened until I was trimming Polyspan on a covering job.

When I opened the package and used one of the blades, I was stunned by how sharp it was. Those guys in the 30s had something going there!

The blades Tim sells are Solingen steel from Germany. They are sharp, in part, because they are thin. The hardware store razor blades are 8/1000 of an inch thick, and the double-edged blades are 3/1000 of an inch thick.

The guys in Denver report that the blades can cut soft 1/8-inch balsa without any tearing. You may need to rig up some kind of holder to use these blades, but they sure look like the ticket for small light models. Goldstein advertises in *SAM Speaks* and the *NFFS Digest* from time to time. If you have an opportunity, buy a box of these razor blades, the true good old stuff.

from the Reno Radio Control Club, Reno NV

Watch out for troublesome ticks

B. T. Lamborn, editor

The weather will be breaking soon and with the warmer weather the residents of Hungry Valley will be out taking in some sun. Some will be objecting to us intruding in their space, and others will be looking for a meal of warm red fluid (your blood). So when you are out in the brush looking for your downed bird, please watch where you are stepping or placing your hands.

If you are bitten by a tick, remove it with tweezers or needlenose pliers close to the skin line. Do not squeeze its body, pour fuel on it, or burn it with a lit

match or cigarette. You will only make it regurgitate, and whatever was inside it will be inside you. Do not discard the tick. Save it and have it tested for diseases by the County Agricultural Agent or your doctor.

There has been much said about Lyme Disease and how difficult it is to cure; however, there is a more insidious disease whose symptoms are similar to Lyme Disease called Ehrlichiosis. This disease is much more difficult to cure. The year of treatments is debilitating, and it has about a 5% mortality rate. So testing the tick can give your doctor a head start on finding out what the problem might be.

Tick facts:

- Ticks carry a variety of diseases. Rocky Mountain spotted fever, Babesiosis (aka Texas fever), Ehrlichiosis, and Tularemia are all transmitted by ticks.
- Ticks tend to hide in damp, shady, and low brush areas until they find a host. They survive on the blood of their host. Some hard ticks feed for hours or even days!

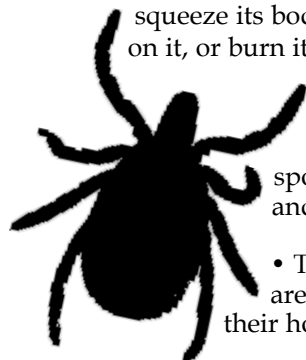

What to look for:

If you suspect you were bitten by a tick here are some Lyme Disease warning signs to look for. Most of these symptoms appear within the first 7 to 14 days after infection:

- **A bull's eye like rash around the bite area.**
- **Fever**
- **Fatigue**
- **Muscle/joint aches**

source: Centers for Disease Control and Prevention

Avoid tick bites by:

- **Wearing light colors when in wooded or grassy areas. Ticks can be spotted on light colors better.**

- **Checking for ticks and removing them early lessens the likelihood of disease transmission.**

source: familydoctor.org

from the Concord Skyhawks RC Club, Bow NH
Rob Lawrence, editor

Word search: Building terms

Y E U L G E T A L Y R C A O N A Y C I P
I C P A A O F N G C P C R E M R O F I F
O N Y J V R P V E T L W Q U G E S T K U
H L G W A B A C O D R V K R Q M Y A C X
K S O G X Y I F X O Z G E E W O C P Y P
J D H N B L B O N O W J W G C T Z X I Z
C A U Z C A G A P W A B F D R O O P D E
V Y P H L G W M U S U T W E O T S V E F
R Z U A V R D S H S G X H T E O R C X S
K P H H N A A O S A Y O N H W O M Y H N
H G D M L E W O T B B W U G A L E P O D
S J J U V Z S L C B Q B Y I P C S B F A
H P F F E H Z E Y W U A P A C V D F G C
P D R T L J D K T L E L Q R H H B U H T
Z G X U G Y N B K I N I G T D M L H S E
H F L N C I U H G K S P N S B B A L S A
D M W G F E E D Y O S S S S U N J N C I
I Q Q E S A N A H E W N U O Y M P W B L
S M P F D S E D R I R J M E Y M R O X P
B M Y R U S Y G O Z S X J G H V W M W Z

DOPE	BASS WOOD	BALSA
EPOXY	STRAIGHTEDGE	SPRUCE
FORMER	CYANOACRYLATE GLUE	MOTO TOOL
BULK HEAD	FOAM	HOBBY KNIFE
	JAPANESE TISSUE	

from the Barnyard Buzzards Model
Airplane Club, Monroe WA

Spring flying check list

by Randy Turner, safety officer
Ron Swift, editor

Editor's note: It's almost spring, and with nice weather comes the urge to fly. Now is the time to check your airplane. Why not make a quick check list?

Start with something like this . . .

- General overall condition
- Hinges—make sure they are tight and not binding
- Bolts, nuts, and screws—make sure they are tight
- Covering—make sure it is tight, not torn, and does not have any small holes
- Servos—make sure it is not binding or loose
- Batteries—make sure they are cycled and charged with no damages or leaks
- Flight box—make sure you have all necessary tools and spare items (this year, how about putting some Band-Aids in your flight box)
- Attitude—make sure you keep it good

NEED MATERIALS FOR YOUR CLUB NEWSLETTER?

Check out www.modelaircraft.org/newsletters.asp.

You'll find every issue of the *National Newsletter* published since 1997.

It's a great resource for construction, safety, and how-to articles as well as hints, jokes, cartoons, and general AMA information.

from the Capital Area Soaring Association, Rockville MD
Keep track of your hobby

by Lawrence Hare
Scott Allen, editor

I keep a log book for each of my aircraft. It is a small ringed notebook, one per airplane, which I assiduously update after each trip to a flying field. Even so, I could not keep track of all costs, modifications, add-ons, and all the other paraphernalia that I would like to keep track of-until I found the Flight Log at: www.lammers.ca/FlightLog/.

I started using it and found it extremely useful. Shawn Lammers, the creator, is constantly updating the program, listening, and helping the users. It is free, although I think he will get an offer eventually, and then it will cost!

He uses a Microsoft Access database as an engine, and is able to pull together different views of equipment, models, log books, transmitters, etc; to provide a variety of reports. Not the least amongst them, and quite fearful in its purport, is a cost summary. Ouch! The amount I spent over the years is, perhaps, best not known, but easily done by simply not entering dollars.



from the New Jersey Pine Barons Radio Control Club, Mt. Laurel NJ

Perfecting the square loop

by Eric Henderson
Glen Grulke, editor

Loops with straight lines can look very attractive if done well. This month we will take on the case of a loop with four straight lines. It may not even look too difficult. New square-loop attempters tend to just pull the elevator hard four times, but loops, as we all know, can be deceiving. You may have performed the perfect square loop; however, to be sure check out the following.

We will begin with a square loop because it is easier to ascertain your success. The square loop belongs to a family of loops with lines. Other loops are the three-sided, the six-sided and the eight-sided, all of which can be performed inverted or right side-up. Additionally they can have a whole range of rolls on the lines. Scared you off yet?

The square loop is much more obviously right or conversely wrong. Humans seem to be able to spot squareness more readily than roundness. This precise maneuver, if done perfectly, is very impressive to watch.

It is comprised of four 90° corners, and four straight lines of equal length. To start, pull the airplane into a quarter-loop from level flight, and climb to a comfortable distance. If your plane starts to lose too much speed, start again and climb for a shorter height or time.

The next element is another quarter-loop. With the airplane inverted, fly the distance as in the vertical climb.

Then pull a third quarter-loop and let the plane head back toward the ground. Our old amigo, gravity, is helping out again. Lastly, the fourth quarter-loop is pulled and level flight is resumed again with a straight line to exactly where the square loop began.

Now let's do that all again with some control input advice. Fly straight across in front of you about

100-yards away. This may be uncomfortable at first but it presents the maneuver in a much more viewable, and possibly favorable light. Select about three-fourth throttle and fly past the imaginary center line in front of you. Pull the quarter-loop and apply full throttle as you begin to go vertical. This will allow you to pull a tighter corner without sliding too far horizontally. Concentrate on holding a vertical line. Do not be surprised if your airplane goes a little to the side. Hold in a little bit of corrective rudder or elevator or both. Before you run out of vertical speed pull the second corner. (It is a good idea to release any corrective inputs, before pulling the corner). Be careful not to pull as much elevator displacement because gravity will be helping and will cause a pinched corner if you let it. You will need to be ready with some down elevator to prevent the airplane from diving while inverted. As the line is being established and held, it is time to slowly come back on the throttle. Some pilots tend to throttle back too quickly causing the plane to slow down and sink. If the aircraft slows too much, you'll need too much down-elevator in a hurry. It is much better to throttle back slowly right up to the third corner.

By now your throttle should be all of the way back. Pull the third corner like you did the second. You are looking for the same radius as the first and second corner. The airplane will gain speed on the down-line, and care should be taken to try and reproduce the curve of the last corner,

You must also avoid stalling the elevator as you pull out of the dive.

The secret is to plan a square loop backwards. Find out what the airplane is capable of on the last corner and start the square loop with that radius. A smart move is to try a few down lines and pullouts to see what both you and your airplane are

see **LOOP** on page 6

Five musts of basic model aircraft set up

John Hice, editor

There are five aspects of aircraft design that are crucial to desired flight performance—call them the Fab Five. There are others, but these five are fundamental, easy to check, and should be understood by every pilot.

They are:

- 1) Balance: fore and aft
- 2) Balance: wing tip to wing tip
- 3) Wing incidence
- 4) Engine thrust line: up or down
- 5) Engine thrust line: left or right

These are all usually specified on plans or building instructions. If not, such as with many almost ready to fly models, it is important to know an appropriate starting point for each, and to verify all five before attempting flight.

Tip-to-tip balance: It is either good or it isn't. You may need help from another person to check it. Hold the front by

the spinner or propeller shaft and the rear at the center of the fuselage. It may help to insert a pin or hook at the rear to aid in suspending the airplane. High wings should be held upside-down. If either wing drops, add weight to the opposite wingtip until balanced. A heavy wing condition will cause the ailerons to trim with one up and one down.

Fore-to-aft balance: The airplane should balance at a point about 25 to 35% back from the LE of the wing. This is the envelope or range of balance that will provide safe, controllable flight.

A tail heavy airplane is unstable in flight, difficult to control, and if excessively tail heavy, it can be unsafe—a danger to persons and property.

A nose-heavy airplane may be difficult to trim in flight, drop the nose when power is reduced, and require a lot of down elevator when inverted.

It's better to be a bit nose heavy, however, than the opposite. Flight testing will determine if a change in balance is desired.

Wing incidence: It is normally a few degrees "positive" for sport flying. This means the LE of the wing is higher than the trailing edge in reference to the plane of the elevator. You can hold a straight edge on top of the elevator surface and draw a line along the fuselage with an erasable pen as a reference line. Then measure from this line to the E and TE to find the incidence. You can plot this on paper and measure the angle.

Flight performance will indicate if a change is necessary. Too much positive will make the airplane climb as power is added, zoom upward when pulling out of a dive, and tend to climb when turning. Negative, or

see **FAB FIVE** on page 8

LOOP continued from page 5)

comfortable with. Armed with this information, you can then plan a square loop that uses this down line radius as the standard for the first, second, and third radii.

There is a common, but very wrong, myth that square loops have to have tight corners. Please ignore any guidance based on this misconception. Equal radii and equal straight lines are the rule. We even have it in writing in the AMA rule book! In fact excessively tight corners are to be considered as a downgrade.

The short form of the above description is to remember that what you are trying to achieve is four equal corners, four equal lines, all in the same plane. You will definitely need a friend to tell you if you are doing this one right. Time and distance awareness will play tricks on you as the airplane changes speed in the four lines.

Some of the hard parts to get right in this maneuver are the different

radii that your airplane will pull at different airspeeds. You will need a lot less up-elevator when pulling the top two corners than when you pull the bottom two.

Wind Correction

Headwind:

- Pull a little less elevator for the upwind corners and more when pulling into the wind.
- Try to lean the airplane into the wind on the up line and the down line. If you don't, the airplane will drift back as you climb.

Crosswind:

- The same rudder is held all the way around, but the plane is leaning off the vertical or horizontal. The smart move is to straighten the airplane up with rudder before or just as you pull the 90° corner. Then put the rudder back in to deal with crosswind only when on the straight lines.

from the Barnyard Buzzards Model Airplane Club, Monroe WA

Recipe: One model airplane club

by Chet Blake
Ron Swift, editor

One large dollop of inventiveness that only model builders possess.

One area where modelers need support to find and keep a flying site.

One smaller group of senior builders who have their feet on the ground.

One appreciative public who stop when they hear the sound of motors.

One great desire to compete and to talk about it forever afterward.

Mix thoroughly, simmer slowly, and spread lightly over the entire community.

Yield: One Model Airplane Club

Make inexpensive wheel brakes with super-spoiler

by Chris Reiser

I really wanted wheel brakes! It was an easy lesson to learn from the jet jockeys. After setting a few brush fires, they can tiptoe out to the flightline and hold at the threshold. After takeoff, they burn a few kerosene-flavored holes in the sky, then land at 100 mph and come to a dainty stop before the middle taxiway. Wheel brakes can do that for you.

Wheel brakes: it's the law. Of course, the *AMA Safety Regulations for Model Aircraft Powered by Gas Turbines* make the point obvious with requirement number six. "The model shall be able to come to a controlled stop on command with the engine at idle on a level hard surface."

After applauding a rare jet flight at the field, it's anticlimactic to taxi out with a beginner's pattern-model. Mine is a 5 lb., 10 oz. Great Planes Venus 40, held in check with a Futaba T6XAS six-channel radio. Being overpowered by Saito 72 four-stroke, buzzing a 12 x 9 APC pattern propeller, it really moves. In fact, it can't stop. It starts to roll when your fingers leave the wing and it doesn't look back. On landing, it idles past

the end of the runway into the weeds. Early on I learned to do sharp S-turns after touchdown just to keep it in sight. After S-turning the foam wheels right off the hubs, I decided I wanted wheel brakes, and I wanted them bad.

The lust lasted a few hours, until the Robart Web site revealed what wheel brakes cost. At roughly \$300, they equal the cost of the airframe. I cried myself to sleep, and dreamt of spoilers and flaps (not very effective during taxi), drogue chutes (hard to deploy reversibly), landing hooks (I can tear my gear out by myself, thank you), and other novelties. I settled on a superspoiler.

After removing the balsa sheeting from the aft 60% of the upper inboard wing, I glued in a layer of sheeting under the existing surface. This made a recessed space 4 x 5.5 inch on each wing, exactly the size of a .020-inch thick aluminum sheet cut to order. The front edges of the two sheets were glued and pinned to a 0.22 inch OD tube, which was free to rotate in three tubular bushings. After some carving in the center and along the spar of the wing, the bushings were glued into the wing so that the sheets rested in the recessed space. A Futaba

FP S148 servo, mounted in the wing midsection, rotated the tube about 85° when the gear switch toggled to the transmitter. The super-spoilers became an integral part of the upper wing surface until deployed, when they form an enormous air brake, right in the propwash. The minimal weight gain did not move the CG so there was no need to rebalance the aircraft.

During taxi, the super-spoiler keeps the Venus 40 from moving when the engine is at idle, a welcome safety feature in the pits. In flight, I could not find a serious behavior change in lift characteristics. Thankfully, the super-spoilers do not spontaneously rise during spins. In fact, the servo lacks the torque to raise the super-spoilers in normal flight, so I just don't use them as air brakes. After landing, the super-spoilers can be deployed, and bring the airplane to a stop before mid-field. The left spoiler tends to rise first; some rudder compensation is needed to achieve a centerline taxi path.

Ok, I know it's fudging it, but it is light, inexpensive, and worked on this model—even though I really wanted wheel brakes.

Build a balance stand

by Joseph M. Nunes
Keith Conrad, editor

If you're tired of balancing your latest aeronautical creation on your fingertips, while at the same time trying to add weight or shifting your radio system around to get the correct location for the center of gravity (CG), then this simple half-hour project could be just what you need. Once you finish it, you'll be wondering why you didn't think of it yourself.

Use of this simple aid to correctly locate the CG will produce a more stable, flyable model. I designed and built mine in one hour for \$1.00. With convenient workshop tools, "around-the-house" materials, and a piece of scrap pine lumber, you too can have a balancer that will serve for a long time.

What you will need:

Lumber:

12 x 6; 1/3-inch thick

Wood dowel:

10 inches long; 5/16-inch diameter

Drill:

5/16-inch bit (for holes)

Eraser:

two pencil-top erasers

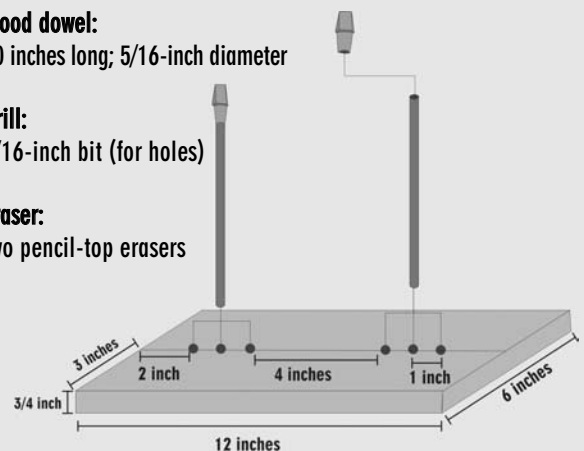

Graphic reproduction by Jessica Booth

too little positive incidence, causes a diving tendency throughout flight.

Engine thrust up or down: A small amount of engine down thrust is common in sport models. It helps to counteract the climbing effect of positive wing incidence as power is added without affecting the glide angle at low throttle. Too much down thrust may require excessive up trim for level flight, and may cause the model to nose up when power is cut. Up thrust will cause the opposite of these.

Engine thrust right or left: Some right engine thrust, usually two or three degrees, is essential to counteract the torque of the engine. If there is too little right thrust, the model will pull to the left as it loses speed in a steep climb. It will also pull to the left at the top of a loop. Too much right thrust will cause the opposite.

Technical Editor's Note: Torque causes the airframe to rotate opposite of the propeller, therefore, right-thrust would have no effect on torque reaction. In fact, most aircraft have their engines set at zero right or left thrust. The turning effect that torque is blamed for happens on the ground at relatively slow speeds. Some claim that the turning effect is due to the P-factor (or P-effect), but that claim runs into large difficulties when you consider that the tricycle geared airframes (the full sized P-38, for example, before the rotation of one of the engines is changed) shows the same tendency to turn right under power while still on the ground.

The flight effects of changes in these Fab Five are contingent upon whether airframe was built and assembled straight and true. A slightly warped wing, cocked rudder, twisted fuselage, etc., can cause similar effects and make it difficult to achieve a well-mannered, predictable model in flight. And everything is a trade-off. Changing one thing will often require changing something else. Be prepared for a lot of checking, trial and error. A good performing plane with no bad habits is worth the effort. It makes flying enjoyable.

from the Prop Masters RC Aero Club, Warrenville IL

Notes from an e-flier

by Mitch Gerdisch
Dave Masters, editor

Flying electric airplanes is just one more facet of this great hobby and more and more pilots are trying electric flight. Therefore, for those budding e-fliers, I thought I would share a few thoughts from my four years of experience in this part of the hobby.

1. Once that battery is plugged in, assume the propeller has only one goal in life and that is to hurt you. Even with throttle locks on transmitters and switches on speed controllers, once you plug that battery in, you want to make sure you keep away from the propeller.

When a gas or glow-motor driven propeller hits something it will generally stall the motor, but not without doing some damage. An electric motor will not stall; it'll just draw more current in an attempt to keep going. So, an electric driven propeller can do much more damage. Thus, it must be given your utmost respect.

The switches on speed controllers are no guarantee either. I've had motors start spinning even with the speed controller switched off.

2. Use quality connectors. I see some folks using Tamiya connectors.

Tamiyas are not really suitable for RC flight since it's not a matter of if they will fail, but rather a matter of when. For small models, Dean's makes micro connectors which are well liked. For larger models, Sermos (AKA Anderson Powerpoles) or Dean's Ultra connectors are liked as well. These are just a couple of choices, but the bottom line is to use a quality connector.

3. Finding a good motor, propeller, and battery combo is a bit science and a bit art. On a glow model, you

generally combine a known engine and a known propeller (eg. .40 engine with a 10 x 5 propeller or something like

that). In electrics, it can be a bit more complicated since you also have to account for the number of cells, plus there are a number of motor and gearbox combinations. The easiest thing to do is simply find a combination someone else is successfully using in a similarly sized model and copy that. One source for this sort of information is the electric power systems forum like www.rcgroups.com.

I hope this helps those thinking about trying out electric flight. And, feel free to contact me at telemitch@wowwav.com if you have any follow-up questions.

**Finding a good motor,
propeller, and battery combo
is a bit science and a bit art.**

coming soon...

Get Ready for the New National Newsletter

**New Look • New Content • New Name
A Great New Resource for Club Officers**

WORKSHOP ASSISTANCE

HINTS & TIPS FROM FELLOW MODELERS

Des Moines Modelaires, Ankeny IA

Adding weight

Ray Pick, editor

Ever have the need to add a little extra weight to the front or tail of your airplane? Instead of purchasing expensive stick-on weights, try the following.

Go to your local tire-repair shop and ask if you can have some used tire weights (the weights they put on tire rims). They come in different sizes and have a clip that you can bend and use it to screw the weight to your airplane. The best thing is, they're free.

Most places are glad to get rid of them. They have to throw them away anyway. I went to Tires-Plus and they gave me several pounds just for the asking!

Madison Area Radio Control Society,
Madison WI

Building board

Jerry Buss, editor

I was just informed about a great building board called Homasote Handi-Board. It can be purchased at Menards in 2 x 4 foot, 1/2-inch thick sheets. It is a gray color and appears to be made of a recycled paper. In order to get a flat sheet, you might want to pull one out near the middle of the stack.

Pins can be pushed into it, and the material absorbs razor-blade cuts without shredding. I laid the sheet on top of my work bench and built right on top of it; however, to prevent globs of hardened glue from making the surface uneven, a sheet of thin poster board could be taped to the top of the Handi-Board and replaced when it gets too messy.

Des Moines Modelaires, Ankeny IA

Keep your pilot in your airplane

Ray Pick, editor

Have you ever seen someone's pilot-figure rolling around in the canopy? Not very cool especially if the pilot is an F-15 figure. Try this idea to make sure your pilot doesn't eject too soon.

Since most pilot figures are hollow, enlarge the rubber hole in the bottom of your figure. Make it about 1/4-inch to 3/8-inch wide. Go down to your favorite hardware store and purchase some drywall hole-hanger screws.

Get the 1/2 inch or 3/4 inch thick size. Which size to use will depend on your cockpit size and the thickness of your pilot's rubber base.

Now drill a hole in the cockpit floor (where your pilot will sit.) The cockpit hole needs to line up with the hole in the bottom of your figure.

Now glue your pilot down and take the drywall screw and push it up through the bottom of the cockpit floor.

Put the base of your figure on top of the drywall screw and tighten the screw. As the screw is tightened, the casing's external fingers will collapse or spread out inside your figure securely attaching your pilot to the cockpit floor.

Now if your airplane crashes, at least you know your pilot will still be securely attached!

I would not waste my life in friction when it could be turned into momentum.

Frances Willard (1839-1898), educator

from the Woodland Aero Modelers,
Woodbridge IL

Using nylon bolts

by Dino Vlahakis, editor

Here is a neat little tip for those nylon wing bolts. Usually they come with round, slotted heads. They work, but your screwdriver has a good chance of going through your wing after it slips during installation.

Take a 7/16-inch hex nut, and run it all the way under the round head on the screw.

Now you can sand the nylon bolt to match the hex pattern on the nut. When the nut is removed, the nylon wing bolt will be transformed into a hex bolt that can be easily tightened with your four-way glow plug wrench.

from the Western New York Free Flight Society, Fairport NY

Get a better bond

by David Rosenberg

Mark C. Rzdaca, editor

Cyanoacrylate (CY) adhesive is triggered by moisture! Wood that becomes too dry from being stored too long in low humidity environments may not have sufficient moisture to activate CY glue. Moisten old balsa wood prior to bonding.

Save that stamp!

If your club newsletter is sent to AMA electronically there is no need to send a hard copy.

E-mail your newsletter to
jessicab@modelaircraft.org